

Presto4U - Grant Agreement no: 600845

Deliverable D4.3 - Recommendations for Standards and Trusted Audiovisual Repositories



**Project Acronym: Presto4U**  
**Grant Agreement no: 600845**  
**Project Title: European Technology for Digital  
Audiovisual Media Preservation**

# Deliverable D4.3 Recommendations for Standards and Trusted Audiovisual Repositories

Project funded by the European Community in the 7<sup>th</sup> Framework Programme



Deliverable D4.3 - Recommendations for Standards and Trusted Audiovisual Repositories

## Table of Contents

[Scope](#)

[Executive Summary](#)

[Acknowledgments](#)

[1. Introduction](#)

[2. Standards, Organisations and Bodies](#)

[2.1 Process for issuing International Standards](#)

[2.2 Standard “producers”](#)

[MPEG](#)

[3. Emerging and evolving standards in audiovisual preservation](#)

[3.1 MP-AF](#)

[3.2 PREMIS](#)

[3.3 MP-AF and PREMIS](#)

[3.4 Media Contract Ontology \(MCO\)](#)

[3.5 Provenance data model and ontology \(W3C PROV\)](#)

[3.6 W3C Web Annotation Working Group](#)

[3.7 EBU SP/Quality Control \(QC\)](#)

[3.8 EBU/AMWA Framework for interoperable media services \(FIMS\)](#)

[3.9 MXF Archiving and Preservation – AS-07](#)

[4. PrestoCentre Standards Register](#)

[4.1 Overview of PrestoCentre Standards Register functionality](#)

[4.2 Standards Register scope](#)

[4.3 Interoperability with other standards initiatives](#)

[5. Use of Standards in audiovisual preservation](#)

[5.1 Footage Sales Libraries](#)

[5.2 Music & Sound Archives](#)

[5.2.1 Case Study - INA: Digitisation of audio content produced by Radio France](#)

[5.2.2 Case Study - INA: Music Production, Post-Production and Electroacoustic composition](#)

[5.3 Personal collections](#)

[5.4 Video production and Post-Production](#)

[5.5 Film Collections and Filmmakers](#)

[5.6 Learning and Teaching Repositories](#)

[5.7 Research and Scientific Collections](#)

[5.8 TV, Radio and New Media Broadcasting](#)

[5.8.1 Case Study - BBC: D3 & DigiBeta Videotape Preservation](#)

[5.8.2 Case Study - RAI: Legacy archive digitisation and preservation](#)

[5.9 Video Art Community of Practice Rights and Standards](#)

[5.10 Use of Standards Case Study: ORF & MXF Overcoming Issues with complex standards](#)

[6. Barriers to adoption of standards](#)

[6.1 Lack of reference implementations](#)

Deliverable D4.3 - Recommendations for Standards and Trusted Audiovisual Repositories

[6.2 Access to specification documents](#)

[6.3 Implementation costs](#)

[6.3.1 Licensing](#)

[6.3.2 Resources required for evaluation](#)

[6.4 Appropriateness](#)

[6.4.1 Complexity or scope of standard related to need](#)

[6.4.2 Cross sector issues](#)

[6.5 Risks to Maturity](#)

[7. Trusted audiovisual repositories](#)

[7.1 Standards for Repository Assessment](#)

[7.1.1 Focus on the Data Seal of Approval](#)

[7.2 Case Studies](#)

[7.2.1 Digital Repository of Ireland \(DRI\) Case Study](#)

[7.2.2 B&G / "Sound and Vision" – "OAIS Compliant Preservation Workflows in an AV Archive"](#)

[7.2.3 Digital Production Partnership – "10 Things You Need to Know About Digital Storage"](#)

[7.3 Conclusions](#)

[8. Conclusion](#)

[Glossary](#)

[References](#)

[Document information](#)

[Document Status Sheet \(Revision History\)](#)

Deliverable D4.3 - Recommendations for Standards and Trusted Audiovisual Repositories

## Scope

The scope of D4.3 is to provide an overview of the importance of standards in audiovisual preservation and their adoption by the multifarious communities involved in preservation workflows. Even within different institutions, Communities of Practice (CoPs) have common needs and face the same challenges in audiovisual preservation. Standards form the backbone of tools and services responding to the needs of those involved in audiovisual preservation by providing reliable and sustainable frameworks around which services can be developed. This report builds upon the knowledge gathered throughout the duration of the project to present guidelines and recommendations on the use of standards and related best practices for long-term audiovisual preservation.

## **Executive Summary**

This document focus on relevant and newborn standards for audiovisual preservation as well as trusted audiovisual repositories. Many standards are currently available for digital preservation but only few are suitable for audiovisual contents. The document provides an overview of the most adopted standards, exploiting the experiences of the Presto4U Communities of Practice: common use cases are reported, highlighting the standards and technologies implemented. Particularly important is the MPEG Multimedia Preservation Application Format (MP-AF), the standard created specifically for preserving audiovisual metadata, which has been successfully supported by the project and provides a novel approach for describing the preservation description information, covering the current gaps left by other digital preservation metadata formats. The document gives also suggestions on what to take care of when asked to select standard and technologies for audiovisual preservation, presenting some highlights as well as barriers and limits of adoption of specific ones. Last part of the document is devoted to the description of the Presto4U standard registry available at the web site and the description of trustworthy repositories for audiovisual archives or digital libraries.

## **Acknowledgments**

We want to give a special thanks to Rebecca Squire Guenther from the PREMIS Editorial Committee and Lisa de Leeuw and Ingrid Dillo from the Data Seal of Approval Board that contributed to this document with specific and detailed sections.

## 1. Introduction

The document provides an overview and state of the art of relevant audiovisual and preservation standards and trusted audiovisual repositories. It is written starting from the internal and interim report D4.2 “Promoting Technology standardisation and services”. Some selected sections (such as Chapter 2 which is a good introduction to what is a standard and describes the work behind the standardisation bodies) have been kept in order to provide a self-contained document, updating information where applicable and adding sections with new results.

Standards in the audiovisual context are changing very rapidly, especially with regards to digital preservation. Since the release of D4.2 at the end of 2013, we have seen the evolution of the MPEG preservation and rights standards as well as the creation of new specific groups (EBU QC and FIMS-QA) for defining and representing quality information. Also the well established digital preservation standard, PREMIS, is still under revision and improvement and gratefully its Editorial Committee contributed to the current document with their latest updates. Specifically concerning audiovisual preservation standards, the Presto4U partners have been involved in MPEG starting from the PrestoPRIME project, setting up the initial request for standards about multimedia metadata. This work lasted for some years and eventually in early 2015 MPEG MP-AF (Multimedia Preservation Application Format) will be issued as Draft International Standard, entering the final steps for its further official publishing as International Standard. The current document provides details about these standards and points out their interrelations and respective strengths, their use within the Presto4U communities of practices as well as the potential barriers that exist to adoption. Concerning Trusted Repositories for Audiovisual, due to the fast growing interest and adoption within preservation communities of the Data Seal of Approval (DSA), a specific section has been dedicated to it with contributions by the DSA Board.

The document is organized as follows: Chapter 2 introduces what standards are and how they are created by the respective standardisation bodies and institutions. Chapter 3 focuses on the emerging and evolving standards in audiovisual preservation, where updates and novel details are provided about MPEG-A part 15 (MP-AF), PREMIS, MPEG-21 part 21, W3C Provenance, W3C Web Annotation, EBU/AMWA FIMS, MXF AS-07. Chapter 4 gives an overview of the current PrestoCentre Standards Register and what is already providing to CoPs concerning multimedia standards.

Chapter 5 deals with the use of standards in audiovisual preservation. Some CoPs best practices are reported, summarizing the more detailed description already given in D4.2.

Chapter 6 analyzes potential barriers to the adoption of standards. This chapter starts from the experience matured from the text presented in D4.1 and points out the potential barriers to specific adoption of standards, such as the accessibility to the related documentation and the availability of reference softwares among others. Chapter 7 introduced what a Trusted Digital Repository is and provides deeper insight into the Data Seal of Approval. This Chapter also provides some use cases captured from the Presto4U’s CoPs.

A final wrap-up about the topic addressed and investigated here is provided in the “Conclusions” Chapter.

## 2. Standards, Organisations and Bodies

There are many definitions for the word “standard”. According to the Encyclopedia Britannica [1], a standard is:

*“A standard is that which has been selected as a model to which objects or actions may be compared. Standards for industry may be devices and instruments used to regulate colour, size, weight, and other product attributes, or they may be physical models. Standards may also be written mathematical or symbolic descriptions, drawings, or formulas setting forth the important features of objects to be produced or actions to be performed. Standards that are applied in an industrial setting include engineering standards, such as properties of materials, fits and tolerances, terminology, and drafting practices; and product standards intended to describe attributes and ingredients of manufactured items and embodied in drawings, formulas, materials lists, descriptions, or models. Certain fundamental standards among firms are required to prevent conflict and duplication of effort. The standards activities of governmental departments, trade associations, and technical associations serve in part to meet national standards needs, but one specialized standardizing organization is needed to coordinate the diverse standardization activities of many different types of organizations and promote general acceptance of basic standards. In the United States the American National Standards Institute (ANSI) performs this function. It does not initiate or write standards but provides the means by which national engineering, safety, and industrial standards can be coordinated. All interested groups may participate in the decision-making process, and compliance with the national standard is voluntary. The international body that serves this function is the International Organization for Standardization (ISO). Developing an international standard presents the greater challenge because of the breadth of representation and the diversity of needs and viewpoints that must be reconciled.”*

whilst the Wikipedia [2] reports as technical standard:

*“A technical standard is an established norm or requirement in regard to technical systems. It is usually a formal document that establishes uniform engineering or technical criteria, methods, processes and practices. In contrast, a custom, convention, company product, corporate standard, etc. that becomes generally accepted and dominant is often called a de facto standard. A technical standard can also be a controlled artifact or similar formal means used for calibration. Reference Standards and certified reference materials have an assigned value by direct comparison with a reference base. A primary standard is usually under the jurisdiction of a national standards body. Secondary, tertiary, check standards and standard materials may be used for reference in a metrology system. A key requirement in this case is (metrological) traceability, an unbroken paper trail of calibrations back to the primary standard.*

*A technical standard may be developed privately or unilaterally, for example by a corporation, regulatory body, military, etc. Standards can also be developed by groups such as trade unions, and trade associations. Standards organizations often have more diverse input and usually develop voluntary standards: these might become mandatory if adopted by a government, business contract, etc. The standardization process may be by edict or may involve the formal consensus of technical experts.”*

At the Library of Congress [3] we have:

## Deliverable D4.3 - Recommendations for Standards and Trusted Audiovisual Repositories

*“Standards are typically generated by governments or the hundreds of U.S. and international professional associations and organizations interested in or affected by the subject matter. .... Standards set the basis for determining consistent and acceptable minimum levels of reliability and safety, and are adhered to either voluntary or as mandated by law.”*

A further definition of standard provided by the MPEG convenor is:

*“Codified agreement between parties recognising the advantage by all doing an agreed number of things in the same way” [4]*

A good reference for standard definition has been reported in 2009 by NIST [5], in the document “The ABC’s of Standard Activities” [6]

According to the aforementioned definitions, a standard has different scopes, from a local specification to international and can be the outcome of an international collaborative process as well as a “de facto standard”. The consensus of technical experts among international standards is guaranteed by national delegations: they represent the country and report suggestions and reactions to be voted. A quick description of the international standard process is reported in a further section.

Digital preservation is a quite young scientific discipline and not many “international standards” are available in this field. Many guidelines and specifications has been created upon best practices and professional analysis and even if some of them are not at all “standard” they must be considered as “de facto standard” because of their widely use and adoption.

It happened to the most widely accepted digital preservation standard, the OAIS [7], that has been analysed originally by a specific community, the CCSDS [8] that firstly had the need to create a common framework for managing the digital preservation.

The former OAIS was just a CCSDS specification. Later on, also due to the great success of their documentation and analysis, the specification was submitted to the ISO that after the usual flow of ballots and votes, made the OAIS the common international standard we know.

### **2.1 Process for issuing International Standards**

When a technical expert or group wants to promote a new specification, it must be proposed to a standardization body. At international level, such as the ISO, it must be formally submitted as new proposal that must be evaluated by the internal technical committees (or subcommittees).

The approval of a new proposal is not given by grant: it must be discussed and must be proven that the proposal is promoting something eligible for the standardization process.

It everything is fine and the proposal succeed the first evaluation, the standardization body issues a formal and open “call for proposals” where everybody in the world can contribute and can suggest candidate solutions to the published topic.

Once gathered these international contributions, if the proposal is still valid and pass the “requirement” evaluation, it can be moved to a more formal “Working Draft (WD)”, that must be discussed within the technical experts and at international level. It must be evaluated several times until its shape is good enough to be issued as “Committee Draft (CD)”. Once CD, the original specification is going to be “publicly” available and every country is formally asked to express his evaluation. An international “formal ballot” is created and the CD cannot move forward if it is not able to receive the formal approval of a minimum number of



## Deliverable D4.3 - Recommendations for Standards and Trusted Audiovisual Repositories

national delegations (5 or more). If it succeeds, the CD can be moved to a “Final Committee Draft (FCD)” and must be submitted for further international ballot and vote. Only and only if all these votes are over the threshold, the FCD is finally approved and becomes “Final Draft International Standard (FDIS)”. Hence a final ballot is issued in order to ask to the national bodies the last approval of the specification that can be moved from FDIS to “International Standard (IS)”.

### 2.2 Standard “producers”

The “technical standard” definition reported above tells us that we can have formal “international standards” issued by official standardization bodies, as well as “de facto standards” issued by any kind of organization, institution or company.

We have at least two main categories that we have to consider in this document: the digital preservation and the AV content standards.

Concerning the former, as mentioned before, the CCSDS has created the OAIS specification, whilst the ISO has issued the related standard. OAIS is for sure one (if not the only) of the most important digital preservation standard: it defines a “de facto” dictionary for any preservation archive. Another important body providing standard specifications is the Library of Congress [9]. In the past they have provided MODS [10], METS [11] and especially PREMIS [12] that can be considered as the most widely adopted best practice in the field of digital preservation metadata structure.

Even if the Library of Congress does not create “international standard” obeying the aforementioned standardization process, their standard specifications such as METS and PREMIS are the most widely adopted “container” the former and “preservation metadata structure” the latter. Many LoC specifications such as Z39.50 are currently provided as International standard by ANSI-NISO bodies and many other are involving NSA and especially NIST.

In the field of AV contents, there are many Industry Consortia that are providing recommendations and “specifications”, such as EBU for what concern the broadcasting production in Europe, or SNIA that deals with storage and network standards.

Concerning official international standardization bodies, relevant for AV contents, we have to cite ISO-IEC, ITU-T and SMPTE that are providing standard specifications for most of the AV formats we are commonly using. Among the others we can highlight MPEG-1,2,3,4,7,21, JPEG and MXF.

Aside these, in the field of AV contents many new formats are provided by W3C [13] that according to their web site, we can describe as an international organization providing “web standards” [14]: *W3C publishes documents that define Web technologies. These documents follow a process designed to promote consensus, fairness, public accountability, and quality. At the end of this process, W3C publishes Recommendations, which are considered Web standards*

### MPEG

Due to the high relevance of MPEG as standardization body for what concern the standard for the preservation of AV contents, we dedicate a specific section here describing a little bit more the internal structure and business model.

Deliverable D4.3 - Recommendations for Standards and Trusted Audiovisual Repositories

The Moving Picture Expert Group is a specific working group operating within the ISO organization. The overall structure is reported in Figure 2.1:

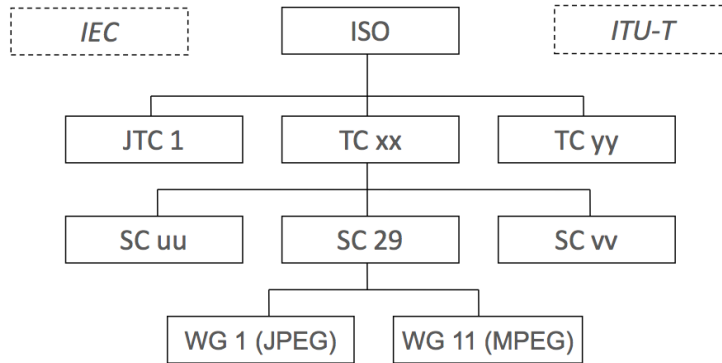

Figure 2.1 - MPEG within the ISO structure (courtesy of L. Chiariglione) [15]

The ISO is made up of several Technical Committee, each one made up of several SubCommittee having Working groups inside.

MPEG is the Working Group number 11 in the SubCommittee number 29, which is part of the Joint Technical Committee number 1 (MPEG = ISO/IEC JTC 1/SC29/WG11)[15]

During more than 25 years of life, MPEG has developed several standards and related technologies. In Figure 2.2 is reported a short list of current MPEG standards.

No	Nick-name	Title
11172	MPEG-1	Coding of moving pictures and associated audio at up to about 1.5 Mbit/s
13818	MPEG-2	Generic coding of moving pictures and associated audio
14496	MPEG-4	Coding of audio-visual objects
15938	MPEG-7	Multimedia Content Description Interface
21000	MPEG-21	Multimedia Framework
23000	MPEG-A	Multimedia Application Formats
23001	MPEG-B	MPEG Systems Technologies
23002	MPEG-C	MPEG Video Technologies
23003	MPEG-D	MPEG Audio Technologies
23004	MPEG-E	MPEG Multimedia Middleware
23005	MPEG-V	Media Context and Control
23006	MPEG-M	Multimedia Service Platform Technologies
23007	MPEG-U	MPEG Rich Media User Interface
23008	MPEG-H	High Efficiency Coding and Media Delivery in Heterogeneous Environments
23009	MPEG-DASH	Dynamic Adaptive Streaming over HTTP

Figure 2.2 - List of number and nicknames of current MPEG standards (courtesy of L. Chiariglione) [15]

Many MPEG standards are in our daily life such as

- the MPEG 1-2 Layer III, commonly known as “mp3”,
- the MPEG-2 Transport Stream, which is the streaming protocol adopted by digital terrestrial television, i.e. the common broadcasted television we are watching at,
- the MPEG-4 AVC (also known as ITU h.264) which is widely used as Internet streaming video format

Deliverable D4.3 - Recommendations for Standards and Trusted Audiovisual Repositories

and since the beginning, the overall approach of MPEG was to provide “standard interfaces”. As reported in Figure 2.3, MPEG is responsible to define the middle-layer, the interface of the bitstream from the provider to the consumer, where a communication channel is in between.

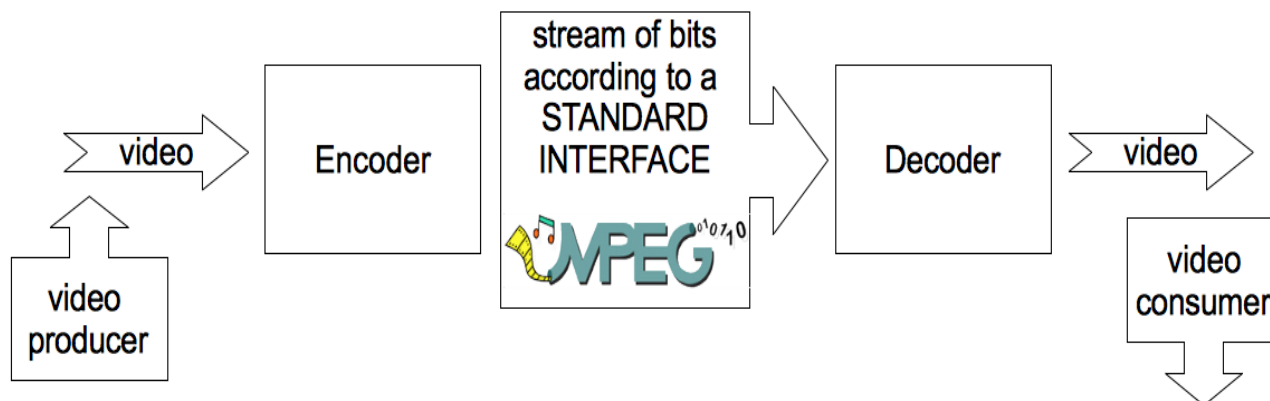

Figure 2.3 MPEG overall approach: it defines the “interfaces” for bitstream transportation from the producer to the consumer of multimedia contents.

This communication channel can be a network as well as “storage” device. MPEG defines the interface of the datastream, nothing else. And here we have the potential impact to the marketplace: it is up to the software vendors to implement the best “Encoder” and “Decoder” compliant to the standard interface. The software vendors can provide these software components under specific licenses, patents or even for free in some cases. The business model is simple and at the same time really powerful and completely open. Many AV companies such as Sony, Panasonic, Samsung, Apple, Microsoft, etc. have strong interests in implementing high performance Encoders and Decoders. They contribute to the interface definition as well but their real interests are in the left and right parts of Figure 2.3.

### **3. Emerging and evolving standards in audiovisual preservation**

This Chapter introduces the emerging standards in audiovisual preservation, mainly dealing with the metadata representation especially tailored to the preservation needs.

Due to the Presto' family background, the involved partners and the special value of this standard in the metadata description for preservation information of audiovisual materials, the first standard reported is the Multimedia Preservation Application Format (MP-AF), in Section 3.1.

Section 3.2 follows, providing more information about the most widely used preservation metadata standard currently adopted in digital archives, the PREMIS, with special attention to new features introduced in the last (still under publishing) version 3.0. Then Section 3.3 provides an overview on the dual importance of both of these standards, where they cross over and the differences between the two. Section 3.4 introduces the Media Contract Ontology (MCO), i.e. the ISO/IEC 21000-21, actually started with the experience of PrestoPRIME project and almost completed at the time of writing. MCO is a successful example of contributions to standardization bodies coming from EU funded projects such as the Presto's family. Section 3.5 describes the latest updates on provenance data model and ontology (W3C PROV), the suite of standards for representing provenance informations developed by W3C. Section 3.6 is devoted to the work undertaken by the Web Annotation Working Group that W3C has launched in late 2014 for defining a generic model for annotating resources on the Web. Section 3.7 reports the EBU SP/Quality Control (QC) activity, the data model that is going to be created and its relationships to audiovisual preservation, whilst Section 3.8 introduces the EBU/AMWA Framework for interoperable media services (FIMS), the task force born in 2009 aimed to define standards enabling a Service Orientated Architecture. Eventually, Section 3.9 gives latests advancements on MXF Archiving and Preservation.

## Deliverable D4.3 - Recommendations for Standards and Trusted Audiovisual Repositories

### 3.1 MP-AF

Many organisations collecting various types of multimedia content, such as archives, libraries, museums, etc. already have digital preservation systems in place. These organisations have often the need to exchange multimedia assets and related metadata, for example:

- to exchange assets between preservation systems/repositories within the organization or with related organizations,
- to change/upgrade their preservation systems,
- to exchange content with service providers, or to
- provide preservation services for other organisations.

When they exchange multimedia assets, they need to include preservation metadata that enables the receiving organisation both to assess the integrity and fidelity of the assets it receives and to establish a baseline for its own curation and use of the assets. In addition to the metadata described above, the receiving organisation also needs information about any preservation processes the assets have undergone, including descriptions of the outcome of such preservation processes. The description may include metadata about content, structure, and quality, as well as technical, historical and editorial information, and information about property and use rights and conditions. A standard is needed that defines the content and format of multimedia preservation description information (MPDI), in order to facilitate interoperability between preservation systems, ensure accurate understanding of the resources exchanges, and reduce the risks of corruption both in the exchange and thereafter (see [96] and linked documents).

MPEG [15] is currently working on a metadata model for multimedia preservation metadata. A standard for preservation description information (PDI [7][8]) of multimedia items complements related standardisation efforts dealing with technical and descriptive metadata and covering the lifecycle of multimedia items. Within MPEG, the work on multimedia preservation is done in the context of application formats, which are standards composed of subsets of different MPEG technologies targeting a specific application scope, and extending them with existing technology from outside MPEG or new technology if needed. The preservation metadata standard is thus named Multimedia Preservation Application Format (MP-AF) [93][96].

### MP-AF DATA MODEL

The MP-AF data model represents metadata for the preservation of a variety of media, such as images, graphics, video, animation, sound and text, and combinations of these. The definition of these elements/classes follows the goal of maximizing interoperability and maintaining compatibility with existing preservation data models. This should facilitate the adoption of MP-AF model among organizations that already use compatible models, at least for data exchange purposes, such as the migration between preservation systems (for software or hardware upgrade for example) or for exchange between repositories.

The MP-AF data model is defined for representing the Multimedia Preservation Description Information (MPDI) needed for discovering, accessing and delivering multimedia resources.

## Deliverable D4.3 - Recommendations for Standards and Trusted Audiovisual Repositories

The specification of MP-AF contains three main components. The first is a high-level data model, specifying the top-level entities and their relations. The second part concerns the specific metadata structures for the different types of preservation metadata covered by MP-AF, modelled as descriptors. Whenever possible, these definitions make use of existing metadata standards, i.e., the specification reuses parts of MPEG-7, MPEG-21 and also defines extensions to existing metadata standards (e.g., MPEG-7). The third part defines a core set of technical and descriptive metadata that is required to ensure minimum interoperability between preservation systems. A serialisation of the MP-AF data model using XML Schema has been specified.

### **Data Model Overview**

The central entities in the model are those representing multimedia content. They are designed to be compatible with the MPEG-21 Digital Items, which hold metadata and references to the actual essence. In order to align the proposed model with other ones used in the media industry four levels of specialisations are defined.

A Preservation Object combines information describing the intellectual and artistic attributes of a Work together with Digital Items that encode the Work. It includes technical, descriptive and preservation metadata and any other information needed to ensure consistent and reliable access to the Digital Item(s) over time. An Asset is a specialisation of Preservation Object aggregating a description of the owner and the owner's rights. These rights are exploitation rights that are different from the usage rights of a Digital Item. This is aligned with the definition of an Asset by the Society of Motion Picture and Television Engineers (SMPTE), which defines assets as being content with associated rights. Preservation Objects may be recursively nested in order to express groups of objects, which constitute a Preservation Object themselves (e.g., tracks of an audio CD vs. the entire CD). In contrast, Groups are explicitly containers of Preservation Objects and not an Preservation Objects themselves (i.e. it a logical grouping such as a broadcasting series).

A Representation is a specific and complete manifestation of the Work. Representations may differ in terms of technical or descriptive properties while sharing the same intellectual and/or descriptive attributes of the Work (e.g. different performances of the same Work, low vs. high definition representations of a movie). A Representation aggregates the whole set of Essences plus any additional metadata needed for a complete presentation of a Work.

Essence is a manifestation of a Work or part of a Work. It refers to the metadata needed for correctly rendering media content including all associated Components.

The Component is the entity holding specific technical metadata supporting the handling of the media resource referenced by a Media Locator (reference or identifier of a storage media volume, Item or part of an Item). Components can be Files or Bitstreams.

Operators are persons, organisations or systems that can be instantiated in form of Agents (persons, organizations) or Tools (hardware devices, software applications). They are involved in a certain Activity with a specific role. Different Agents may have relations to each other. An Activity is a preservation action performed on at least one Digital Item or Component. The activity is carried out by one or more Operators known to the preservation system.

Deliverable D4.3 - Recommendations for Standards and Trusted Audiovisual Repositories

The complete data model is shown in Figure 3.1. The relations in this diagram are of the following types: inheritance (the entity is a specialization of a more general type inheriting the parent's attributes), composition/aggregation (the entity aggregates other entities) or associations.

The data model contains entities marked with the <<Metadata>> stereotype, which correspond to the metadata types specified in the MP-AF requirements. These entities might correspond to a single or a set of the descriptors in a concrete representation of the model. MP-AF makes use of a number of different existing specifications to represent the preservation metadata descriptors of the entities in the data model. Table 3.1 provides an overview of these specifications.

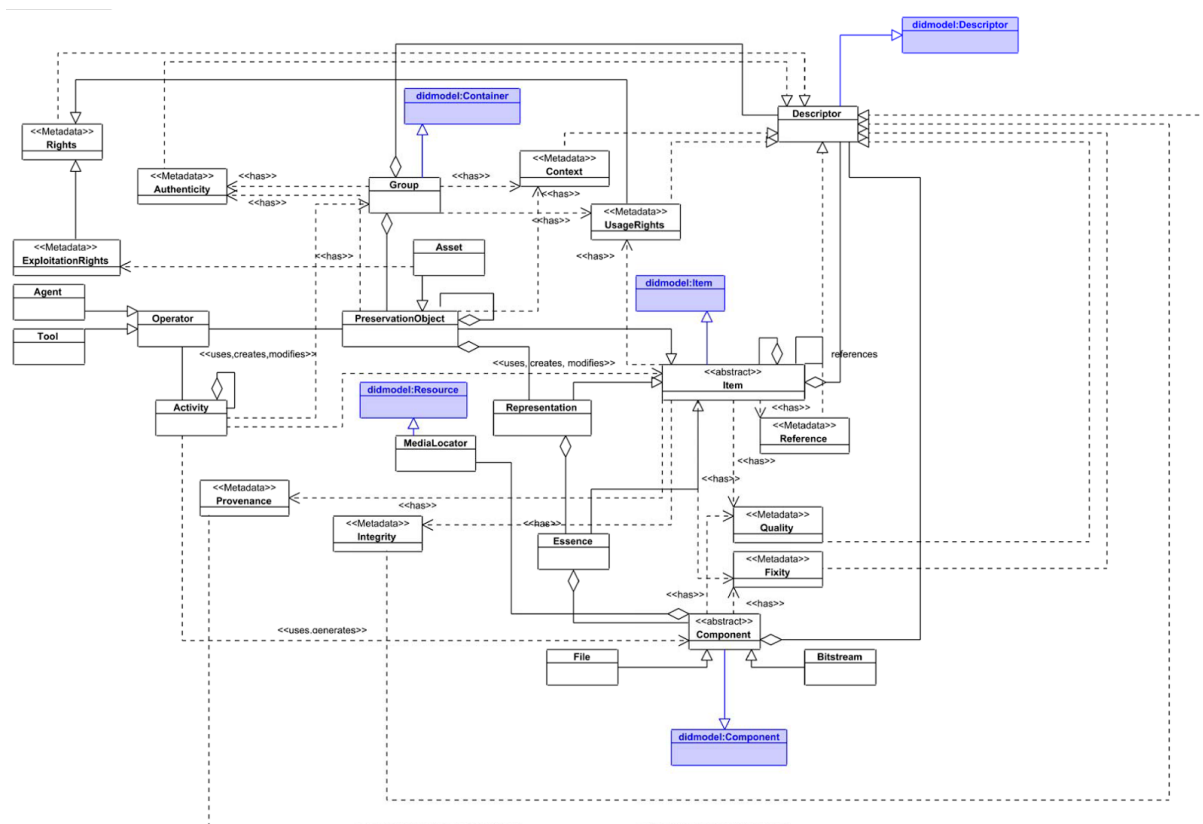

Figure 3.1 - MP-AF Data Model. Entities highlighted in blue are MPEG-21 DID entities.

Provenance	MPEG-21 Digital Item Identification/Description
Descriptive MD	MPEG-7, Dublin Core, EBU Core
Technical MD	MPEG-7, EBU Core
Context, Reference	MPEG-21 Digital Item Semantic Relationships
Quality	MPEG-7 MDS/Amd 5, compatible to EBU QC model

Deliverable D4.3 - Recommendations for Standards and Trusted Audiovisual Repositories

Rights	MPEG-21 Rights Expression Language (REL), MPEG-21 Contract Expression Language (CEL)/Media Contract Ontology (MCO)
--------	--

Table 3.1 - MP-AF, External Metadata specifications used in MP-AF for different types of preservation metadata.

### 3.2 PREMIS

The PREMIS Data Dictionary for Preservation Metadata (PREservation Metadata: Implementation Strategies [16]) is a de facto standard that defines the information you need to know to support long-term digital preservation. An international Working Group comprised of representatives from a wide range of institutions and communities with a deep pool of experience setting up and managing digital preservation initiatives collaborated to create a comprehensive view of the information needed to support digital preservation with guidelines for metadata creation and use. The standard was initially released as version 1.0 in 2005. As of this writing, version 2.2 of the PREMIS Data Dictionary is the current one, although version 3 is almost complete.

Preservation metadata answers a number of questions that support the preservation of digital objects over time. It deals with provenance (who has had custody or ownership of the object?), authenticity (is the object what it purports to be?), preservation activity (what has been done to preserve it?), technical environment (what is needed to render and use it?) and rights (what intellectual property rights must be preserved and what actions are granted by the rightsholder to the repository for carrying out preservation actions?).

The original PREMIS Working Group limited the scope of the Data Dictionary for practical and strategic reasons. The undertaking was considerable given the variety of digital formats, repository systems, institutional policies, and preservation capabilities. If the Data Dictionary covered in detail all metadata pertaining to digital preservation it may never have been completed. In addition it strived to be implementation neutral, defining the information you need to know to preserve your digital objects without regard to what type of repository system you use, the particular preservation strategy, or how you encode the data. It includes technical metadata pertaining to all or most format types, although acknowledging the importance of format-specific technical metadata, which is handled by external standards. Another important factor in digital preservation is business rules of the repository, but PREMIS does not attempt to cover these and they must be part of the local implementation. It provides an XML schema and an OWL ontology [17] for XML and RDF implementation, respectively, but does not require its use. The PREMIS semantic units may be implemented in other ways (e.g. a database, another markup, a spreadsheet). Rights information is generally limited to preservation rights, although an expansion of this area in recent revisions has provided the flexibility to use it more broadly to express intellectual property rights as well.



Deliverable D4.3 - Recommendations for Standards and Trusted Audiovisual Repositories

The PREMIS OWL ontology is available to encode the metadata in RDF formats, allowing for its use as Linked Data. It can be leveraged to have a Linked Data-friendly data management function for a preservation repository, allowing for SPARQL querying. In addition it integrates PREMIS information with other Linked Data compliant datasets, especially format registries and controlled vocabularies that are used to provide values for PREMIS semantic units [18].

The PREMIS Data Dictionary is based on a data model that defines the entities that are described in metadata. The primary entities are Object, Event, Agent and Rights; Intellectual Entities were separate entities but not fully described in PREMIS other than by an identifier. (PREMIS version 3, which is expected to be completed by the end of 2014, revises the data model to make Intellectual Entities another type of Object.) The Data Dictionary is organized by these primary entities, defining “semantic units”, which are properties of the specific entity.

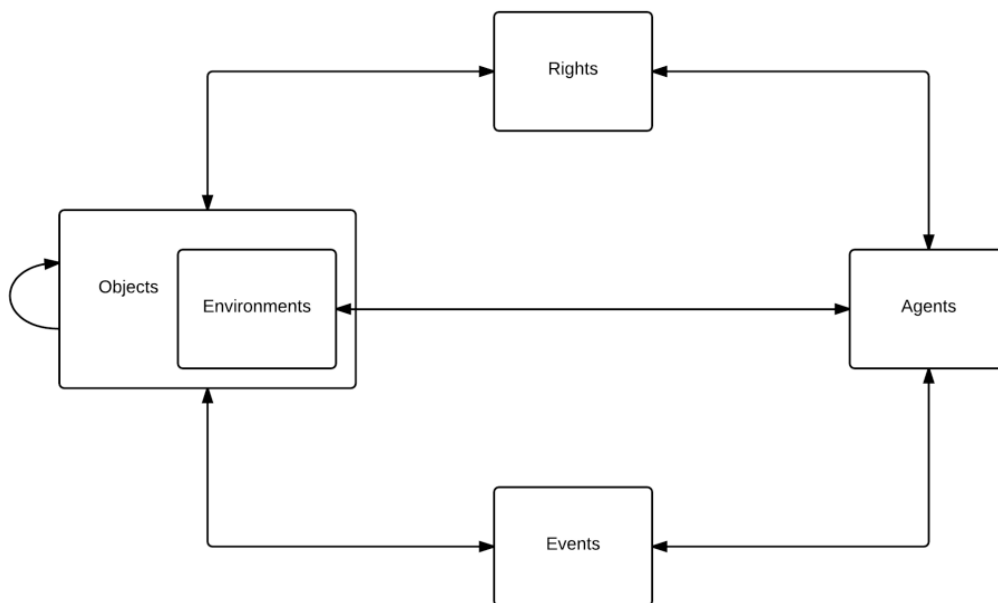

Figure 3.2 PREMIS Data Model, version 3.0

Objects include properties that are primarily technical characteristics and are what the repository actually preserves. The PREMIS Data Dictionary defines three levels of objects: representations (a set of files with structural metadata that provide a complete rendering of the object of preservation), files, and bitstreams. Semantic units are used to manage the object in the repository, identify preservation risks, plan preservation actions and evaluate results of migration processes. Since PREMIS descriptions of objects only give technical characteristics that apply to all or most format types, additional technical metadata is needed

### Deliverable D4.3 - Recommendations for Standards and Trusted Audiovisual Repositories

to fully support the digital preservation process, and PREMIS provides an extension mechanism to include externally defined format-specific technical metadata. In the case of audiovisual materials, where such technical metadata is of increased importance because of their formats, the compound nature of audiovisual objects, and their dependencies on software, external schemas enhance the core PREMIS Object metadata, such as MPEG7 and MPEG21, EBU Core [19], PBCore [20], SMPTE RP210 [21], AES metadata standards [22], audioMD and videoMD [23].

Events detail actions that have been taken on objects for preservation purposes, allowing you to track digital provenance by keeping track of events that have occurred through the lifecycle of the object, including information such as event type, date/time, and event outcomes. Agents are persons, organizations or software that have performed preservation functions on objects or are associated with Rights; these are only minimally described in PREMIS. Rights detail agreements with a rights holder for the repository to take actions on objects; these are categorized as rights by virtue of copyright, license, statute, or local policy. PREMIS also provides the ability to show relationships between the core entities as well as relationships between objects, including derivative and structural relationships, which is done by means of unique identifiers.

In terms of the Open Archival Information System (OAIS) Information model, semantic units in PREMIS fit into Preservation Description Information and Representation Information. OAIS provides a broad reference model of the entities that make up a repository, while PREMIS provides detailed information that can be used to support the automated functions of preservation repositories. It provides the metadata that becomes part of a Submission Information Package, an Archival Information Package and a Dissemination Information Package. It is often used within a container format, and has been widely implemented within the Metadata Encoding and Transmission Standard (METS) [24], which provides for a mechanism to package together the preservation objects, a variety of kinds of metadata, and the structural information needed to use and understand them.

Preserving audiovisual materials requires extensive information because of their compound and complex nature. Many Objects (i.e. files, bitstreams) may comprise an intellectual entity that is the focus of digital preservation, and there must be a means to package these and understand the structure. Because of their time-based nature, this may include information on sequencing as well as how individual components relate to each other. Audiovisual materials require frequent migrations and transformations so that they remain accessible, and there are often dependencies on software and hardware environments. Documenting structural and derivative relationships is of utmost importance.

PREMIS provides the key pieces of information needed to support long-term preservation of audiovisual materials, which are increasingly being transformed into or created in digital formats. It provides the mechanism to detail structural relationships for compound objects, using the multiple levels of Objects (representations, files, bitstreams) defined in the PREMIS Data Dictionary. Derivative relationships are documented and linked to the events

## Deliverable D4.3 - Recommendations for Standards and Trusted Audiovisual Repositories

that initiated them. PREMIS has a rich event model, which is of particular importance for audiovisual materials, requiring tracking events throughout their lifecycle, including documenting the tools and services used.

As of this writing, the PREMIS Editorial Committee is about to complete version 3, which changes the data model by including Intellectual Entities as another level of PREMIS Object and by enhancing the descriptions of hardware and software environments that will enable more robust preservation of them. Because audiovisual materials often have dependencies on specific and sometimes proprietary hardware and software, these changes will enable better linking between objects and the environments needed to use them in the future.

### 3.3 MP-AF and PREMIS

PREMIS is nowadays the (de facto) standard which is used by many national libraries (as example the Library of Congress, the New Zealand National Library, etc.) and archives for aggregating and preserving metadata required for ensuring long term access to digital content. Key concerns are related to the renderability, understandability and identity of digital objects with the passing of time. Repositories that store the digital items related metadata, must ensure their consistency over time. The standard makes no assumptions about the preservation strategies, technologies and storage systems. It is meant to be used on any type of digital content in any available encoding (i.e. file format). PREMIS defines the dictionary of preservation metadata elements, but not the structure of the description resp. the metadata container. It thus needs to be embedded in some container structure, for example, METS or MPEG-21 DID. This way, one can aggregate more complex archiving structures related to book collections, movie series, photo exhibitions, etc. When using the PREMIS standard in a concrete application scenario, it is soon observed that different enhancements are required to address particular needs of a given preservation context [25]. In particular, the following issues have been recognised in the context of preservation metadata for audiovisual content.

#### **Compatibility with standards in use.**

MPEG standards are widely used by broadcasters and audiovisual archives. The information relevant for preservation purposes is partly covered by descriptive and technical metadata standards already in use. Compatibility with these formats eliminates the overhead required for mapping and transforming existing metadata to PREMIS representation and may ease acquisition of preservation related metadata during content creation (e.g., collection of timing and location metadata with digital cameras, metadata acquisition at digitisation time).

#### **Enhanced support for modelling hierarchical, complex structures and descriptions.**

A collection is a common unit of work in digital libraries and archives. Collections may be aggregated in hierarchical structures by using different criteria. Multimedia content is often the result of a long and complicated creation process, reusing material from a multitude of sources, each with their specific properties, provenance and rights. For example, it is popular nowadays to have long TV series organised in seasons and episodes, including

## Deliverable D4.3 - Recommendations for Standards and Trusted Audiovisual Repositories

versions translated in different languages. Motion pictures may be released in a number of localised and age versions, with different audio formats, in different 3D technologies etc. Moreover, the file formats for encoding this content is a container itself carrying bitstreams of different types of data: audio, video, subtitles, etc. Over its lifetime, the content may need to be migrated due to obsolescence of the original formats. For ensuring the long term access to the content by respecting copyrights and ownership, it is mandatory to preserve descriptive and technical metadata at each level of aggregation.

### **Support for time-based metadata.**

The existence of a temporal dimension is an inherent property of audiovisual content. For many types of metadata, it is crucial to have them on a detailed temporal granularity, for example, per shot. This includes descriptive and technical information, which may differ as the shots may be recorded with different technologies. In types of productions that rely heavily on the reuse of material (e.g., news), each shot may come from a different source, having its specific provenance and rights metadata. Due to the potentially long duration of a content item and its large file size, it is also important to have quality and fixity metadata on a fine temporal granularity in order to locate and potentially repair problems in later steps of a preservation workflow.

### **Defining the metadata container.**

The PREMIS standard does per se not specify the metadata container, for example, for the creation of submission, archival and dissemination packages as defined in the OAIS standard. As the choice of the container is left to the implementation, there are no built-in mechanism for ensuring the referential and data integrity of the package. Consequently in the case of broken packages there is no mechanism defined for verifying which parts of the package are not corrupted and can still be used properly in preservation processes.

MP-AF aims to address these issues by defining a specification that provides solutions for these gaps. Compatibility with PREMIS has been taken into account in the design of the standard, and mapping is intended to be straightforward for overlapping parts of the specifications. Moreover, the MP-AF representation takes into account additional issues related to the encoding the metadata in different languages using alternative scripting variants and extendable semantics of the core elements by using controlled vocabularies. By standardising the format of the metadata container and referencing within of the information package a better support for implementation of preservation workflows and outsourcing of preservation services can be provided. The interoperability with other existing data models related to digital preservation has been adopted as a core design principle of MP-AF. The purpose of MP-AF is not to provide yet another metadata standard, but the most interoperable and complete metadata standard for describing the preservation information needed in professional audiovisual domains. Three data models have been selected as the most adopted in the current practice of audiovisual archives, and therefore as mapping targets: PREMIS, W3C PROV and EBU CCDM.

The compatibility of the MP-AF data model with the Object-Event-Agent structure in PREMIS is important in order to support organisations holding some amounts of audiovisual content, but which is not their main asset (e.g. National Libraries may preserve some audiovisual

Deliverable D4.3 - Recommendations for Standards and Trusted Audiovisual Repositories

content, but their core assets are the book collections). Moreover the interoperability increases with the changes planned for the upcoming version 3 of PREMIS. As shown in Figure 3.3, the central element of the data model is the `premis:IntellectualEntity` that in MP-AF is the `PreservationObject` i.e. the entity that the model is describing with preservation metadata. In Figure 1 an UML dependency (dashed arrow) has been depicted connecting the two elements. Actually the `PreservationObject` is a child of the abstract element `Item` that in PREMIS can be considered as a child of `premis:Object`. The MP-AF `Representation`, `File`, `Bitstream` and `UsageRights` have quite straightforward PREMIS counterparts: the `premis:Representation`, `premis:File`, `premis:Bitstream` and `premis:Rights`. Concerning the latter, the MP-AF is more expressive because it can express usage rights (the rights expressed in `premis:Rights`) but can also express the `ExploitationRights`, i.e. much more complex rights (such as contracts) that can prevent many operations on the `PreservationObject` and must be captured as well.

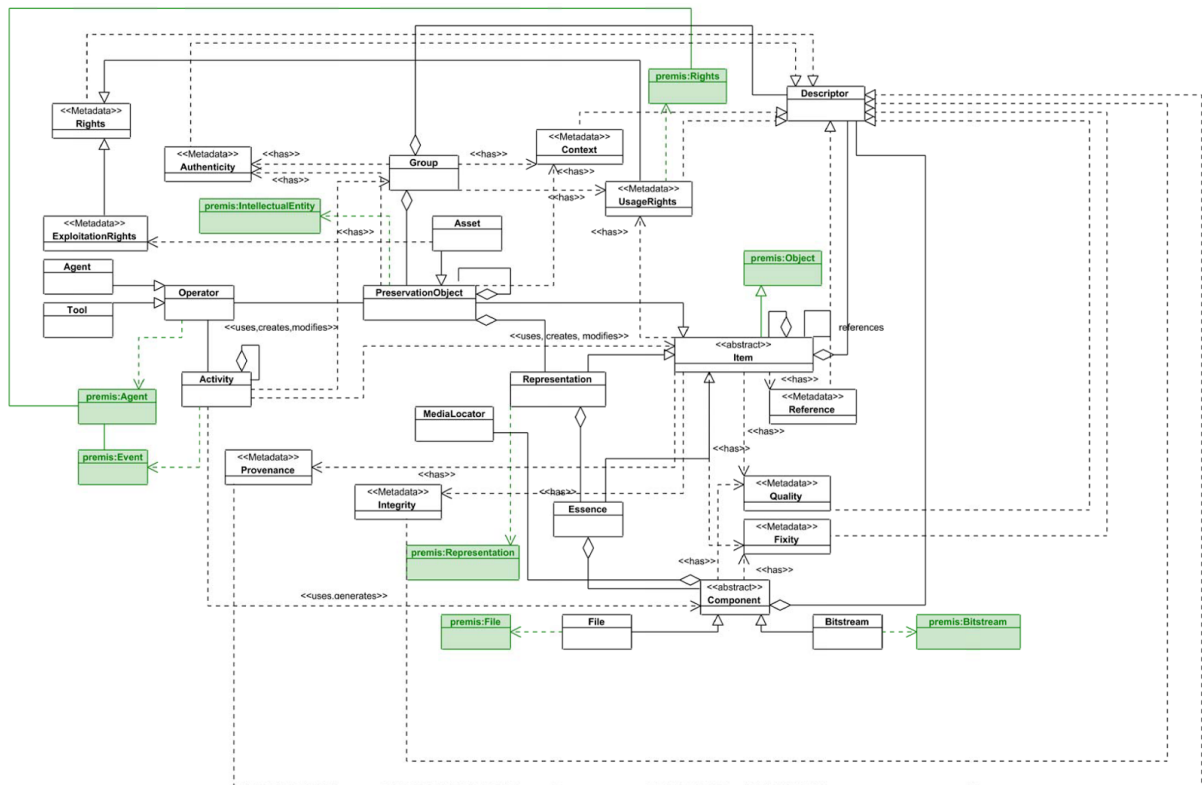

Figure 3.3 - Mapping between MP-AF and PREMIS (highlighted) entities

The MP-AF `Operator` has the related element `premis:Agent`. In this case, MP-AF has decided to discriminate between human beings and machines, that is not directly possible in PREMIS. Hence the MP-AF `Operator` is a superclass of `Agent` for human beings and of `Tools` for software or other virtual actors. It follows that the `premis:Agent` had to be mapped to the more general parent class `Operator`. The MP-AF `Activity`, which is quite general, can be mapped to the `premis:Event`, that is associated to the `premis:Agent` performing or involved in the event as well as the `Activity` is associated to the `Operator` in MP-AF.

Deliverable D4.3 - Recommendations for Standards and Trusted Audiovisual Repositories

**3.4 Media Contract Ontology (MCO)**

ISO/IEC 21000-21 is MPEG-21 part 21: Media Contract Ontology (MCO). Standard published in 2013. A corrigendum was approved in year 2014.

This standard is one of the two electronic formats for the representation of media contracts, resulting from the latest initiative in MPEG-21 framework, the other one being CEL (Contract Expression Language, also published in 2013 as ISO/IEC 21000-20, that is MPEG-21 part 20).

Both CEL and MCO address the same set of requirements and both are organised in core/extensions mechanism. The core part supports the identification of the contract itself, the relationships with pre-existing contracts, the identification of the parties, the identification of the object of the contract, and the definition of deontic-expressions (permissions, obligation, prohibitions), with support to complex logical constructs, signatures and encryption (partial or complete). For both standards the first defined extension address the “exploitation of intellectual property rights” (IPRE).

While CEL is purposely defined as an XML format, normatively specified by XML Schemas, MCO is clearly an OWL-based format and it is explicitly based on the Media Value Chain Ontology (MVCO), which is MPEG-21 part 19, standard published in 2010. The need for implementing correctly MCO as extension of MVCO was the major reason for the MCO Corrigendum in 2014.

The standardization of MCO is the result of the proposals based on the outcomes of the PrestoPRIME project [26].

Although the text of the specification is available for purchase at [www.iso.ch](http://www.iso.ch), the two ontologies mco-core.owl and mco-ipre.owl are publicly available resources.

An informative documentation for the two ontologies is available at the following persistent links:

- <http://purl.oclc.org/NET/mco-core>
- <http://purl.oclc.org/NET/mco-ipre>

The main elements of MCO contracts are represented in the diagram below.

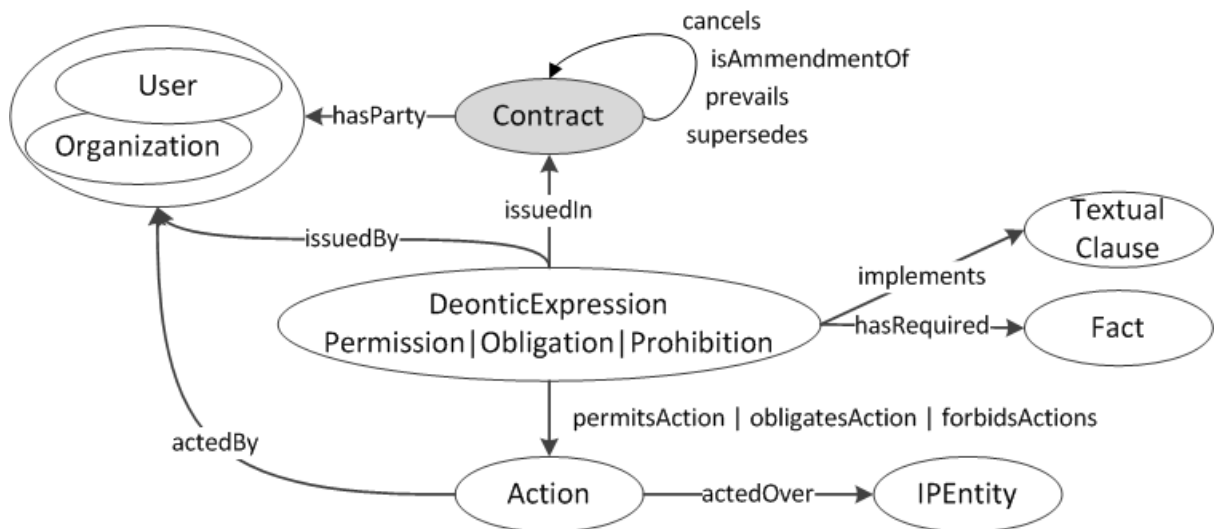

Figure 3.4 Main elements of MCO contracts

### Deliverable D4.3 - Recommendations for Standards and Trusted Audiovisual Repositories

In MCO-IPRE the possible defined “actions”, under the generic exploitation of intellectual property rights, are those mentioned in the common legal framework, specifically: “Fixate”, “Transform”, Duplicate”, “Distribute”, “Public-Performance”, and “Communication-to-the-Public”.

Such basic rights are then refined within contracts by the definition of conditions. MCO allows the expression of conditions by requiring a number of “Facts” to be true, in order to make a deontic expression valid. MCO-IPRE defines a hierarchy of exploitation conditions which cover, with the desired degree of generality/specificity, the various dimensions actually used in real contracts, and specifically:

- the Access Policy - which can be “free of charge” or “pay” under various forms;
- the Means - i.e. conditions on the technology;
- the Delivery Modality - which can be “linear” (i.e. simultaneously to many users) or “non “non linear” (i.e.at the moment chosen by the end user and at her individual request, a.k.a. “make available”) under various forms;
- the Service Access Policy - which can be “open” or “restricted”;
- the Device - i.e. conditions on the end user’s device for content fruition;
- the User Time Access - which can be “limited” (e.g. as for rental) or “unlimited”;
- the Run - i.e. conditions on the number of times which an action is executed;
- the Temporal Context - which is the license period;
- the Spatial Context - which is the territory;
- the Language - of the communication to the public (e.g. dubbing or subtitles);
- the Length - the duration of the content resulting from the action;
- the IPEntity Context - a condition on the content to be used within a specified editorial context.

Two other smart mechanisms are present in MCO for the definition of conditions:

- logical expression of Facts (negation, intersection and union) - for example a condition on the technology can be defined as an alternative between two or more means, doesn’t matter which one; or defining a negative spatial context (anywhere but not in a specified country);
- inter-dependency between deontic expressions - one being valid according to the start or completion of an action permitted or obligated or forbidden by another deontic expression.

The latter mechanism can be used for addressing real cases such as the so-called “catchup-TV” (right to make available content on the web in period of time related to its broadcast) or “cascading series” (stopping rights on episodes of series in relation with the publication of the last episode), and so on.

In the second part of 2014, within MPEG, a further progress of the Media Contract Ontology is envisaged. Likely with the intention of maintaining the conceptual duality with CEL. The areas of work are the following:

- Proposal of Amendment to IPRE extensions
  - extend hierarchical concepts to CEL;
  - add other exploitation conditions for covering restrictions on format and quality, on networks and services;

Deliverable D4.3 - Recommendations for Standards and Trusted Audiovisual Repositories

- add other specification of the “Restricted” conditions, specifying Hotels and transportations (airplanes, ships);
- add other useful information properties, related to the moral rights (authors) and to the status of public domain or other particular status;
- Proposal of Amendment related to new Publish/Subscribe Application Format (PS-AF), where “senders do not communicate information directly to intended receivers but rely instead on a service that mediates the relationship between senders and receivers” [27];
- Ensure interoperability with other standards.

The prompt adoption of MPEG-21 latest specified parts, namely CEL and MCO, for tools and services supporting electronic management of rights would be beneficiary. Both formats are also indicated as relevant options for representing rights information in the Multimedia Preservation Application Format (MP-AF).

MCO is within the wide framework of knowledge representation based on ontologies. This permits to establish knowledge links among different areas, for example between content description and rights, or to take advantage from the contribution of other rights expression initiatives, such as ODRL 2.0, the approach of which is much in line with that of MCO.

### 3.5 Provenance data model and ontology (W3C PROV)

The W3C has developed a suite of standards for representing provenance information for any kind of data [28], which has become a recommendation in April 2013. The suite’s main components are the provenance data model (PROV-DM), and its representations: plain text, XML and RDF/OWL ontology (PROV-O) [29]. The main entities of the data model are shown in Figure 3.5: Agent, Entity and Activity. The model provides some extension points for typing the entities and their relations, as well as adding additional properties.

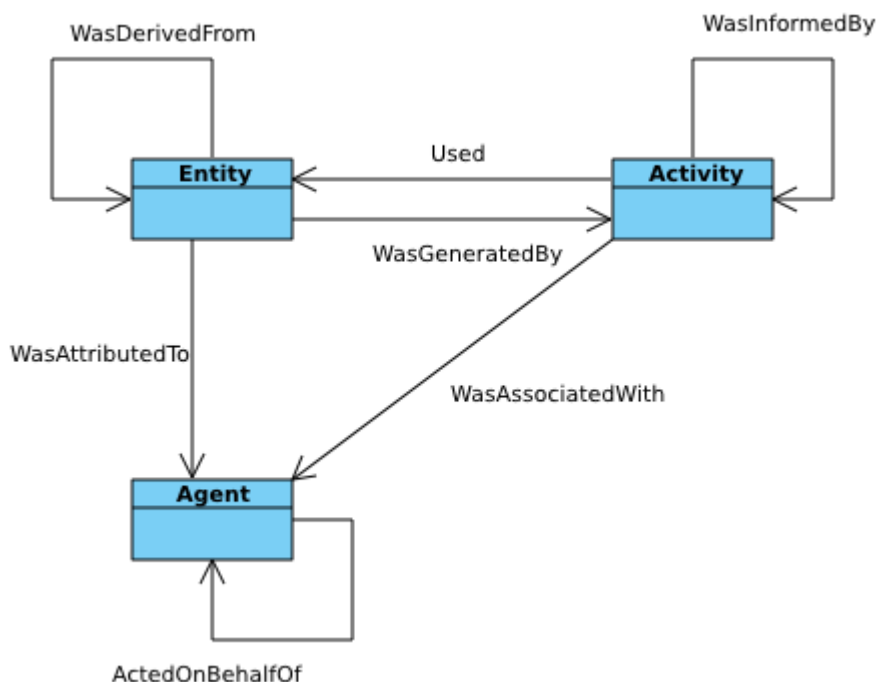



Deliverable D4.3 - Recommendations for Standards and Trusted Audiovisual Repositories

Figure 3.5 - Core entities and relations of the W3C Provenance data model [29].

The model is applicable to describing the provenance of audiovisual content. With the three core classes (not using Rights as in PREMIS) the model is easier to map to other models in the audiovisual domain. The W3C PROV model provides hooks for refinement of types and relations, which also enables to adjust the model more specifically to activities and agents in preservation processes of audiovisual media. In the context of audiovisual data, Entity has to be understood as also involving fragments of content (using e.g. W3C URI for Media Fragments to identify the entity).

The model is thus a candidate to fill the gap of detailed description of both editorial provenance and preservation actions of audiovisual content.

**3.6 W3C Web Annotation Working Group**

In autumn 2014, the W3C has launched an effort to define a generic model for annotating resources on the Web, called the Web Annotation Working Group [30].

An important input to this the Open Annotation Model proposed by Haslhofer et al. [31] as an interoperable approach to relate annotations to objects (called targets). The framework consists of a small ontology relating the target (which can be a resource of any type) to a body, i.e., the actual annotation object (see Figure 3.6). This construction allows also expressing annotations about annotations, as well as annotations represented as any type of multimedia content. The model defines a number of extensions modules. One deals with specifiers, such as selectors (e.g., for media fragments) and states, which allow specifying changing annotations over time). Another extension deals with modelling choices, lists and composites, and a third one with publishing related constructs. This includes a recommended serialisation using JSON-LD as well as definitions for embedding resources and RDF graphs. The model also supports a basic notion of provenance metadata by annotating agents performing the annotation, and a mapping to the W3C Provenance Model (discussed below) is also provided. The Open Annotation Model has been developed as a W3C Community Draft [32].

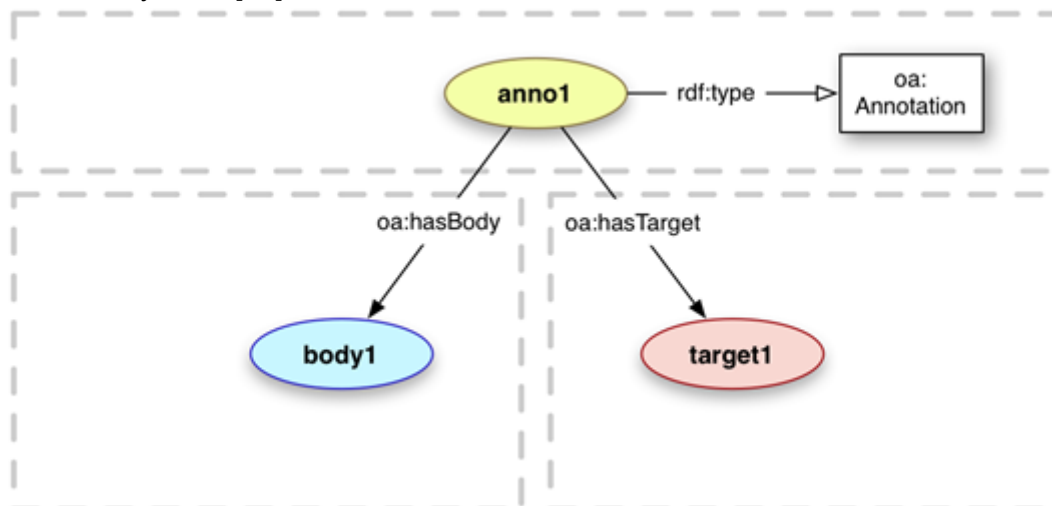

## Deliverable D4.3 - Recommendations for Standards and Trusted Audiovisual Repositories

*Figure 3.6: Core of the Open Annotation Model.*

The Web Annotation WG group aims at developing six outputs:

- Abstract Data Model: An abstract data model for annotations
- Vocabulary: A precise vocabulary describing/defining the data model
- Serializations: one or more serialization formats of the abstract data model, such as JSON/JSON-LD or HTML
- HTTP API: An API specification to create, edit, access, search, manage, and otherwise manipulate annotations through HTTP
- Client-side API: A script interface and events to ease the creation of annotation systems in a browser, a reading system, or a JavaScript plugin
- Robust Link Anchoring: One or more mechanisms to determine a selected range of text or portion of media that may serve as a target for an annotation within, in a predictable and interoperable manner, with allowance for some degree of document changes; these mechanisms must work in HTML5, and must provide an extension point for additional media types and formats.

### **3.7 EBU SP/Quality Control (QC)**

EBU (European Broadcasting Union) is a well-known organisation that collects over 70 European broadcasters with the mission to defend the interests of public service media and to promote their indispensable contribution to modern society. It is a strong point of reference for industry knowledge and expertise. The EBU promotes a media world based on open standards, with interoperability across the value chain and neutral access to all services on all significant platforms. The EBU's Technology & Innovation Department [33] carries on the practical activities by means of working groups specialised in several aspects and covering the production, delivery and service areas.

In particular, the EBU QC strategic programme, takes care of Quality Control of the media content, especially in the new and pervasive file-based environments. Within the Information Technology settings the quality control process can be highly automated but still requires manual checks for final decisions and subjective evaluation. There have been identified four main areas of application: 1) Ingest, 2) Legacy archive transfer to files, 3) Final programme delivery, 4) Programme exchange; being the first two most important in the context of long term preservation.

The group started in 2011 and in the first phase worked mostly for the collection of requirements for automated QC, taking into consideration the real necessities of the participating broadcasters and what the technology can do today and research foresee to do in the future. Until now non automatable checks have been kept in the list, waiting for smarter algorithms and software, and those analysis are marked as manual. From August 2013 a provisional list of checks and analysis (EBU Tech 3363) is publicly available with a basic description on what a QC tool is expected to achieve whilst addressing involved standards. Since then a lot of work has been done in order to refine the list and to better

Deliverable D4.3 - Recommendations for Standards and Trusted Audiovisual Repositories

describe the interfaces of those tests, now called QCItems. For each of them a fixed EBU ID and name is provided together with aliases and most notably a precise list of inputs (thresholds and tolerances) and outputs.

One of the important aspects to consider is the QC reporting that potentially includes detailed and structured information also hooked to essence tracks, time intervals or spatial regions of the video component. Imagine for example a tool reporting the time intervals where the audio loudness exceeds a certain threshold. Given the importance of the reporting, a specific QC subgroup span off from the main one, with the primary target of providing a reference data-model for the QC output. The figure below represents the UML diagram of that model, that at the time of writing is in finalization stage.

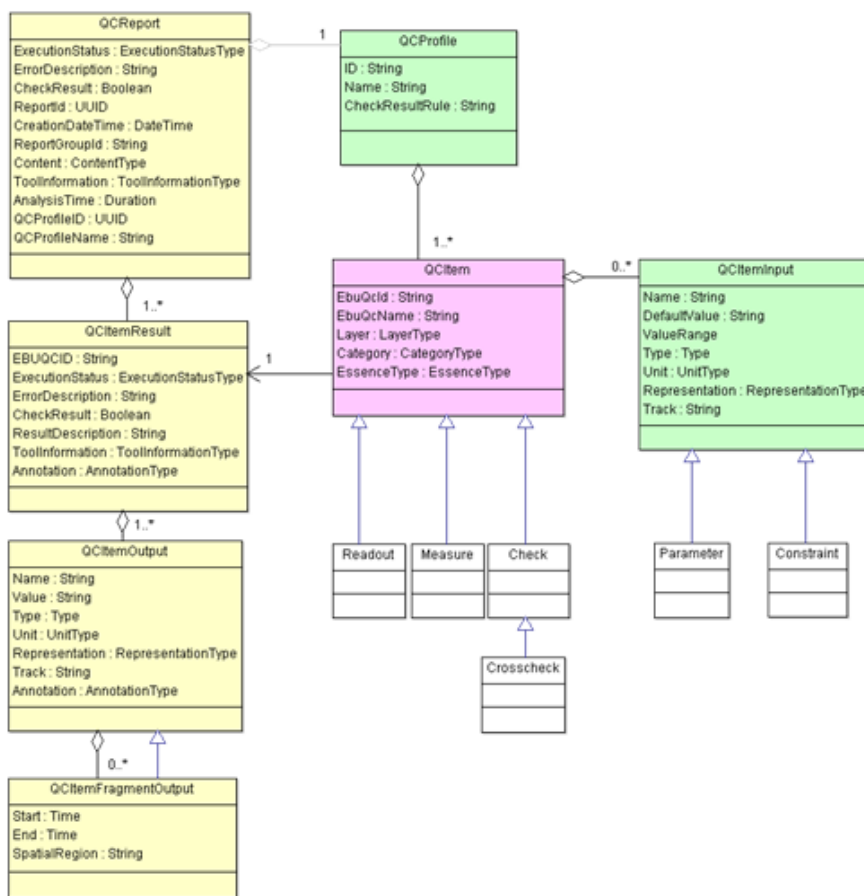

Figure 3.7 UML diagram of EBU QC data model

That analysis is actually in the process of being completed and it has already been shared and discussed with other international organizations, namely MPEG within the Multimedia Preservation Group and the EBU/AMWA FIMS with the FIMS-QA initiative.

In the context of preservation the key concept is that when preparing a DIP to be preserved, the workflow shall prepare accurately all the digital items to be included, taking care not only to what is needed, but also to the quality of the essences. This means checking the conformance of multimedia files to the relevant standards, the technical properties like aspect ratio and resolution and also the intrinsic baseband quality of the audio and video

Deliverable D4.3 - Recommendations for Standards and Trusted Audiovisual Repositories

tracks. All the information coming out of that quality controls has then to be stored, together with the other metadata in order to certify the quality at the moment of ingest into the archive and to leverage a long term process aimed also at quality preservation. Inside the MPEG MP-AF emerging standard (see Chapter 3.1), QC metadata are explicitly considered as one of the seven area of Multimedia Preservation Description Information.

### 3.8 EBU/AMWA Framework for interoperable media services (FIMS)

FIMS (Framework for Interoperable Media Services) [34] is a task force born in 2009 intended to define standards which enable media systems to be built using a Service Orientated Architecture. FIMS is managed jointly by the AMWA (Advanced Media Workflow Association) which is an open community-driven association focused on networked media workflows and the EBU.

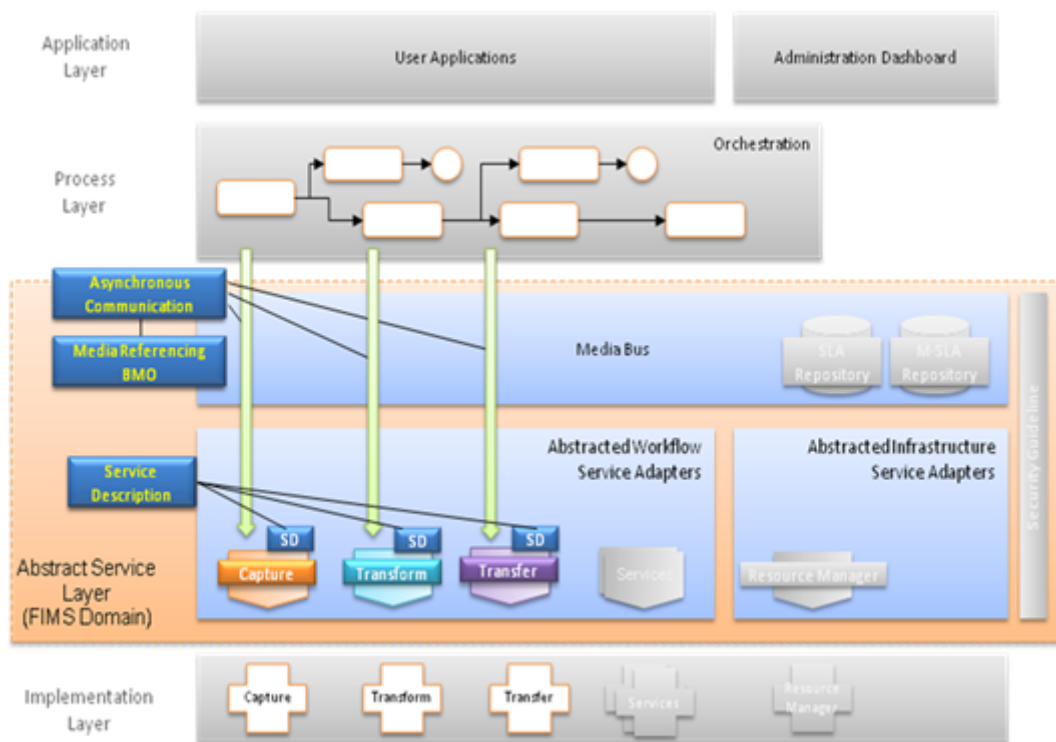

Figure 3.8 - Overall reference model of FIMS Framework

The FIMS 1.0 (v1.0.7) specification was formally approved by the AMWA and the EBU in September 2011, and comprises Part 1, the General Description, and Part 2, a multi-section document describing the Base Schema and the Transfer, Transform and Capture Services. The Figure 3.8, taken from the EBU technical specification 3356-1 (FIMS Media SOA Framework V 1.1) shows the overall reference model of the FIMS framework. In simple words the role of FIMS is to provide an abstraction layer between media processing

#### Deliverable D4.3 - Recommendations for Standards and Trusted Audiovisual Repositories

components and the orchestration engine that implements the business processes required by the users, who interact with the system via an application layer, out of scope from the FIMS perspective.

One practical goal of FIMS is to define web service interfaces (SOAP or REST) for the most important digital multimedia workflows areas like content Capture, Transform, Transfer, Repository, Quality Analysis, Automated Metadata Extraction. When stable, specifications are published as EBU Technical documents and as SMPTE RDD free of charge, together with reference implementations.

All the identified area are involved in the workflow of long term preservation: Capture in the process of digitalization or a more generic migration to file, Repository for storing resources, Transform for format migration (e.g. from one file format to another), Transfer for the network transfer of the multimedia content, Quality Analysis for checking audiovisual baseband quality and file conformance, Metadata Extraction for content enrichment (e.g. face detection or speech to text).

In 2013, FIMS has start a project on Quality Analysis (FIMS QA), aiming at the definition of a service interface and report format for automatic analysis tools. For the definition of quality reporting, FIMS QA gathered requirements from broadcasters in a first phase and more recently got the basic reporting data-model from the EBU QC working group. In summer 2014 FIMS QA is finalizing the first implementation of the QA service interface together with an XML schema of the reporting data-model.

In 2014 also the Metadata Extraction project has start and is inspiring to the work done for the Quality Analysis service towards a generalization of the interfaces and the reporting (quality analysis is a particular case of metadata extraction).

### **3.9 MXF Archiving and Preservation - AS-07**

The Advanced Media Workflow Association (the AMWA) publishes Application Specifications (AS) which are designed to "constrain a standard – like MXF – to suit a specific application" [35]. Application Specification 07 (AS-07) is currently being developed and is described as "a vendor neutral sub-set of MXF for long-term archiving and preservation of moving image essence and associated materials including audio, still images, captions and metadata" [36]. At the time of writing, a draft of this specification is available with a final publication date not set – therefore the details given here may be revised prior to any final publication of the specification.

The full specification is very broad allowing for many possible archive scenarios. For example, an AS-07 file could: represent a whole collection of items (e.g. different versions of a programme episode) with references to the external files in which each of these items is held; or contain the video of a programme that was originated as a file using the original video coding (as long as a mapping to MXF exists). However, it is unlikely that the complete specification will be implemented; instead, it is the "shims" that are most likely to be used (a "shim" is a profile of the main specification).

### Deliverable D4.3 - Recommendations for Standards and Trusted Audiovisual Repositories

The only shim currently defined is the "Baseband Shim". This imposes a number of restrictions on the full specification and so simplifies it to some degree. It is designed to address the main use case of the Federal Agencies Digitization Guidelines Initiative Audio-Visual Working Group [37], which involves the production of files from analogue and digital carriers (e.g. videotapes) or "live" streams. Some of the key components that can be included in MXF files adhering to this shim are:

- Video uncompressed or compressed with JPEG 2000 (lossless or lossy compression)
- Unconstrained number of uncompressed (PCM) audio channels
- Captions, subtitles and timed text
- "Master" and historical timecodes
- Descriptive metadata about the programme, content provenance, etc
- Arbitrary "associated" files / data e.g. scripts, promotional stills / images, etc
- Individual per-frame checksums for the time-based contents of the MXF file

It is clear that this shim still offers a great deal of flexibility. This is undoubtedly required in order to cope with the vast range of historical material from which files may need to be generated. However, such flexibility does make interoperability more challenging. Although unclear how much demand there is to be able to exchange AS-07 files between different archives, there is almost certainly benefit in using a file format that is supported by multiple tools: there are immediate practical benefits as well as the increased likelihood of long term support.

A number of the components allowed by the shim are not mandatory. It could well be that only some of the components are used in common practice and so, in effect, a sub-shim emerges. For example, the AS-07 specification itself recognises the overlap with other "packaging" or "formatting" specifications / standards such as the Archive eXchange Format (AXF) and the BagIt specification. It may well, in practice, be advisable to use solutions such as these to create a bundle of "associated" files rather than using the mechanism provided by AS-07 to embed them in the MXF file.

There is an argument that using a specialist file format for the archiving of professional media (which is itself a niche area relative to the global use of IT) reduces the likelihood of long term support because the file format will never be in particularly widespread use. On the other hand, it would be challenging to accurately capture all the details of the historical media sources without such a file format; and using a format that makes use of published standards is of great benefit. The uptake of AS-07 will be a crucial factor in its utility: sample MXF files are currently being constructed and the Library of Congress intend to make use of the format.

## 4. PrestoCentre Standards Register

Standards should be the invisible framework ensuring products and services used in preservation workflows are both reliable and sustainable. Many standards exist and multiple initiatives have attempted to create standalone registers or to incorporate standards information into their websites as a means to educate and inform users.

Development of the Standards Register involved research into both previous and current initiatives that have included standards as a component of their project or institutional outcomes. By acknowledging past initiatives we can learn lessons on structure, impact and sustainability. By working with current initiatives, such as APARSEN, we can acknowledge our points of commonality and our different focus to foster an open exchange of ideas and promote interoperability across initiatives.

In the following we have listed some examples of initiatives publishing information relating to standards.

- NoE APARSEN Standards focused on scientific and technical activities [38]
- The European standardisation guidelines, standardisation policies and rules [39]
- Digital Curation Centre Standards Register & Standards Framework [40]
- Nestor list of standards [41]
- Library of Congress list of standards [42]
- Digital Preservation Coalition – File formats and standards [43]
- Audio Engineering Society standards [44]
- JISC Metadata standards and interoperability [45]
- SAA External digitisation standards [46]

The Presto4U project has created an interconnected set of communities involved in digital audiovisual preservation.

- Film Collections and Filmmakers
- Footage Sales Libraries
- Learning and Teaching Repositories
- Music and Sound Archives
- Personal Audiovisual Collections
- Research and Scientific Collections
- TV, Radio and New Media Broadcasting
- Video Art, Art Museums and Galleries
- Video Production and Postproduction

Each community varies in their knowledge and use of standards. Project input from these CoPs pointed to a desire to be seen to be compliant with standards while acknowledging that they need to discover more about standards pertinent to their digital collections. The ubiquitous use of the web as a means to discover information begs the question “why create a standards register dedicated to the needs of the audiovisual preservation communities?” and it is precisely the nature of the internet and the vast distribution of knowledge throughout

## Deliverable D4.3 - Recommendations for Standards and Trusted Audiovisual Repositories

it that provides the answer. By aggregating knowledge that is most pertinent to those involved in digital audiovisual preservation, we are creating a dedicated portal for the exploration and display of standards that are most relevant to those workflows. The impact of the Standards Register is further strengthened by soliciting the views of experts within each Community of Practice on the standards they currently use, and an idea of the standards they are seeking further information on. By centring the Standards Register round these Communities of Practice we are recognising that, while there are commonly used standards across all communities in digital audiovisual preservation, differing communities employ some standards more than others and can act as a means of educating other communities on the scope of standards available. For example, while METS [47] is a metadata standard that is relevant to all forms of preservation workflows, AudioMD [48] is an xml schema more suited to those with sound collections.

### **4.1 Overview of PrestoCentre Standards Register functionality**

The Standards Register incorporates information on standards for content and metadata used across all communities involved in audiovisual digital preservation and takes into account the knowledge schema developed in Work Package 2.

The Register provides:

- A description of each standard relevant to audiovisual preservation;
- Logical relationships between standards that are common across all Communities of Practice;
- Logical relationships between standards that are unique to individual Communities of Practice;
- Links to relevant examples of standards;
- Links to documentation and resources on the implementation of standards;
- Users the ability to request standards to be added to the register.

Development of the Standards Register focused on two key areas of the PrestoCentre website

- Integration with the PrestoCentre homepage
- Standards Register landing page

#### **4.1.1 PrestoCentre Homepage Integration**

As a powerful new output on Prestocentre, the Standards Register is prominent on the homepage of the website [49]. The Register has been integrated into the new 'Market Place' homepage, which brings together individual project outcomes like the Community Spaces, the Tech Watch reports, the Tools Catalogue and the recently developed brokerage service (PrestoCentre Broker).



Deliverable D4.3 - Recommendations for Standards and Trusted Audiovisual Repositories



Figure 4.1 - Standards Register on the new 'Market Place' homepage on www.prestocentre.org

The Standards Register has been released as “beta” to allow further evaluation and testing during the remainder of the project. Some improvements are also expected in 2015 by the PrestoCentre.

This service is available to anyone signing up to PrestoCentre — either as a free or as paying member. By clicking on the Standard Register window user are directed to a popup that provides a brief description of the tool.



Figure 4.2 - Standards Register popup on the new 'Market Place' homepage

## Deliverable D4.3 - Recommendations for Standards and Trusted Audiovisual Repositories

It is also adjacent to “Hot Topics” with a dynamic rollover displaying standards relevant to different communities. Clicking on any standard in this rollover takes the user to that record page.

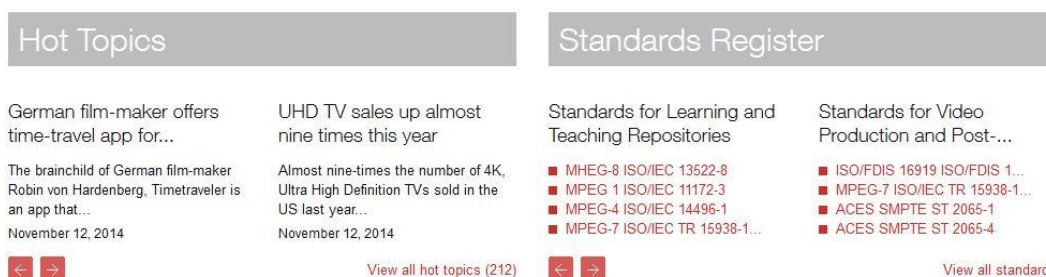

Figure 4.3 - Standards Register on PrestoCentre homepage

### 4.1.2 Standards Register Landing Page

As the entry point to the Register it was important to develop a specification that would create a crisp and immediate point of entry. The list view of columns presents users with a snapshot of the fields from the record pages, with facets to encourage users to browse through different levels of information. In addition, users have the ability to query resources on PrestoCentre in a variety of ways.

- The pre-existing “Search site” capability allows users to search across all resources on the PrestoCentre website
- “Search standards register” provides a more guided search only within resources attached to the Standards Register.
- Users may also request for a standard to be added to the register, once it has been moderated by PrestoCentre.

Deliverable D4.3 - Recommendations for Standards and Trusted Audiovisual Repositories

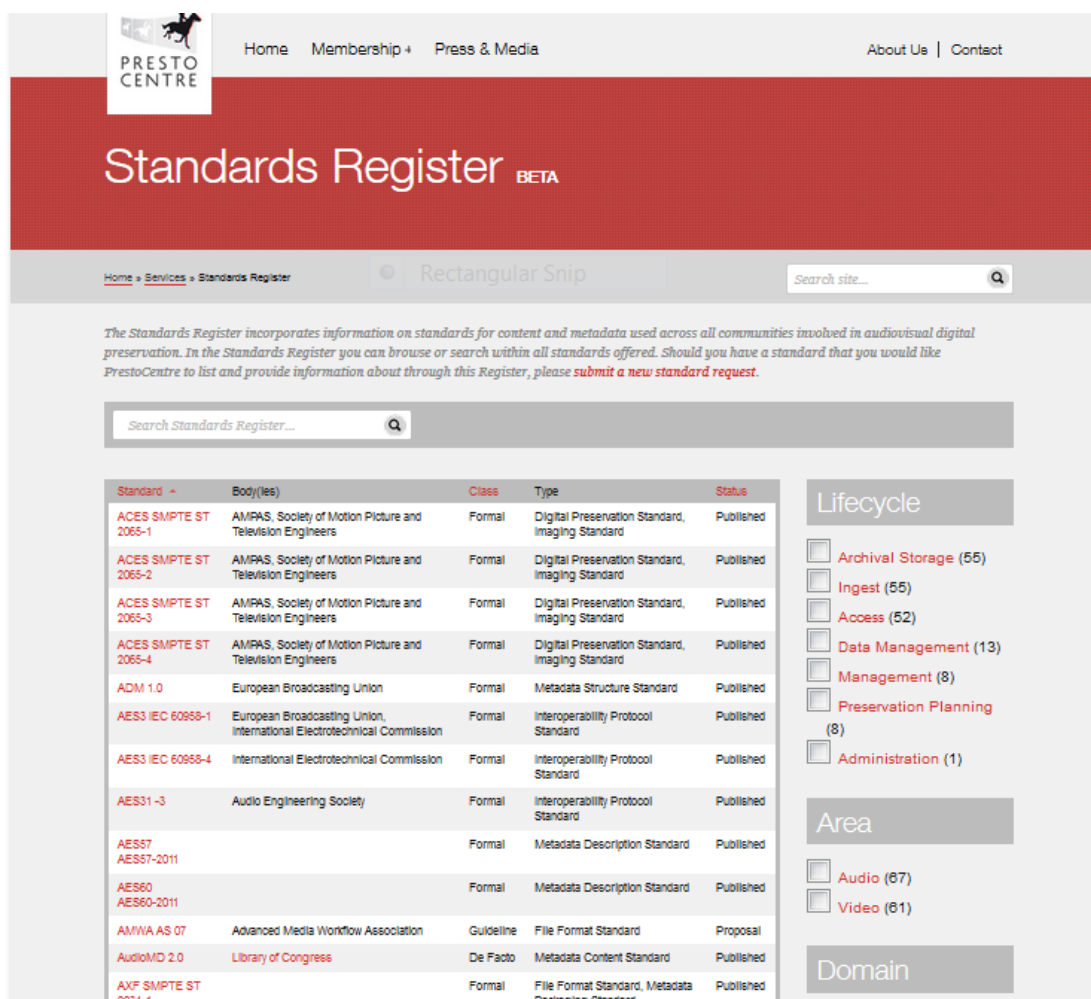

Figure 4.4 - Standards Register landing page

### 4.1.3 Standards Register Record Page

The record page has been specified to present three sections of information to users as we guide them through the use of standards for preservation workflows:

#### **Description fields**

are the fields needed to basically identify the standards with name, versions, description, issuer, references and tags.

#### **Classification fields**

are those fields needed to describe the type, class and scope of a standard and its importance to the Communities of Practices.

#### **Sustainability Factors fields**

are referring to fields that have impact on the future planning for digital preservation activities. This category comprises the fields needed for evaluating the obsolescence and the reliability in the next future of the standard, including community adoption of standards, license information, supporting documentation or resources.

Deliverable D4.3 - Recommendations for Standards and Trusted Audiovisual Repositories

**Description Fields**

**Name**

The name and version of a standard

**Version Date**

Date expressed in any date form. YYYY, MMYYY or DDMMYYYY

**Detailed Name**

Full name of the Standard, without abbreviations

**Other Versions**

Version number(s) of any previous version of a standard, linking that number to a separate record in the Register

Register will contain multiple records for some standards as accompanying tools may not always use the most current version of a standard

**Description**

Full description of the standard with citations for links of information reproduced from other authority sources.

**Status**

Vocabulary based on the maturity of a standard from a guideline to a published standard

**Reference**

Link to the authority website or page within that website with information on a standard. For example: METS [50]

**Tags**

User generated tags for description, subject, etc.

Deliverable D4.3 - Recommendations for Standards and Trusted Audiovisual Repositories

Figure 4.5 - Standards Register record page – Description fields

**Classification Fields**

**Class**

Vocabulary based on the maturity of a standard from a guideline to a published standard

**Type**

Classification of a standard, such as File Packaging Format or Metadata Description Standards

**Geographic Scope**

The geographic scope of a standard, whether worldwide, region or country-based

**Audiovisual Lifecycle**

Classification of records based on the OAIS lifecycle model

## Deliverable D4.3 - Recommendations for Standards and Trusted Audiovisual Repositories

### **Affiliated with/Derived from**

Express the parent/child relationship or other form of relationships between standards. For example, METS [51] in relation to MARC21 [52].

### **Domain**

List of the Communities of Practice that a standard is relevant to



Classification	
<b>Class:</b>	Formal
<b>Type:</b>	Digital Preservation Standard Imaging Standard
<b>Geographic scope:</b>	World
<b>Audiovisual lifecycle:</b>	Archival Storage Ingest Preservation Planning
<b>Affiliated with / Derived from:</b>	ACES
<b>Domain:</b>	Film Collections and Filmmakers TV, Radio and New Media Broadcasting Video Production and Post-Production

Figure 4.6 – Standards Register record page – Classification fields

### **Sustainability Factors**

#### **License and Adoption**

License model

Express whether a license is attached to a standard, with controlled vocabulary of license types

License fee

Express whether a fee is applicable for use of a standard

Community adoption

The representation of a sliding scale from light to dark to illustrate those Communities of Practice who have actively adopted use of a standard. Controlled vocabulary to express the formal names of the communities.

Implemented at

Sequential list of individual organisations who have implemented a standard with a hotlink (where applicable) back to that organisation or to records illustrating use of a standard within that organisation.

#### **Documentation**

Available

Yes/No representation of the availability of documentation, such as the specification of schema relating to a standard

Deliverable D4.3 - Recommendations for Standards and Trusted Audiovisual Repositories

Fee

Indication if a fee is applicable to access documentation

Resources

Sequential list with hot links (where applicable) to related resources such as white papers, tools, etc. that will encourage knowledge transfer

The screenshot displays the 'Sustainability Factors' section of a Standards Register record page. It is divided into two main sub-sections: 'Licence and Adoption' and 'Documentation'.  
**Licence and Adoption:**  
- **Licence model:** Open  
- **Licence fee:** No  
- **Community adoption:** This section includes two progress bars. The first bar is for 'TV, Radio and New Media Broadcasting' and the second is for 'Learning and Teaching Repositories'. Both bars show a green segment on the left labeled 'low' and a white segment on the right labeled 'high', indicating a low level of adoption.  
- **Implemented at:** (This field is currently empty).  
**Documentation:**  
- **Available:** Yes. A link to 'IETF Internet Draft - Full Specification' is provided.  
- **Fee:** No.  
- **Resources:** A list of resources is provided, including a link to the Wikipedia page for Baglt, an introductory video from the Library of Congress, and documentation and tools for Baglt in the PrestoCentre library.

Figure 4.7 – Standards Register record page – Sustainability Factors fields

## Deliverable D4.3 - Recommendations for Standards and Trusted Audiovisual Repositories

**Create Standard version**

Home » Create Standard version Search site...

Relevant standard version  
Check this box if you want the standard version to appear in the standards register search results. If this box is not checked, the standard version will be referenced from other standard versions of the same standard but will not be directly accessible from the standards register search result.

**Descriptive fields**

Version \*

Official notation of version of the standard (appears right next to the standard's [family name], e.g. [MXF] SMPTE ST 381-2 or [MPEG-2] ISO/IEC 13818-1).

Version date  
Day Month Year

Detailed name \*

The text should be displayed as the official abbreviation (where applicable) followed by a dash then the full text name, e.g. METS - Metadata Encoding and Transmission Standard.

Status \*

Choose from taxonomy.

Description

Figure 4.8. Standards Register record creation page – excerpted

### 4.2 Standards Register scope

As a register that is dedicated to the needs of audiovisuals preservation, it was imperative to identify those standards that were of particular interest and use to those communities. While many standards such as METS [53], OAIS [54] or Bagit [55] span multiple disciplines and are not specific to audiovisual preservation workflows while other such as AudioMD and PBCore have been developed to respond to the particular needs of those involved with audiovisual materials.

The Communities of Practice were polled on their knowledge and use of standards within their organisations as a preliminary benchmark on the scope of the Standards Register. Use cases were gathered from the following institutions:

- RAI – Legacy archive digitisation and preservation
- BBC - D3 and DigiBeta Videotape Preservation
- INA – Digitisation of audio content produced by Radio France
- INA – Music Production, PostProduction and Electroacoustic Composition
- Tate Gallery – Artistic/creative AV Content “Tape to File” Process

Standards gathered through this exercise included:

- SMPTE 377-1 MXF File Format Specification [56]



#### Deliverable D4.3 - Recommendations for Standards and Trusted Audiovisual Repositories

- SMPTE 356M-2001 D10 Stream Specification [57]
- METS [58]
- PREMIS [59]

Experts [60] within the field of standards, particularly those involved with audiovisual materials, were also solicited to expand the scope of the register by highlighting standards that may not currently be in use by the CoPs but are important to consider. Together these inputs resulted in a register that presents a strong core knowledge base on standards related to the access and preservation of digital audiovisual materials.

The Standards Register currently holds over seventy records related to audiovisual preservation. Classified by Type, the records cover all stages of preservation workflows with records from all major standards organisations from the European Broadcasting Union to SMPTE, Library of Congress to SMPTE, ISO, MPEG, and many more.

#### Controlled Vocabulary for Standard Type:

- Authentication Standard
- Authorisation Standard
- Authority Standard
- Classification Standard
- Design Standard
- Digital Preservation Standard
- File Format Standard
- File Packaging Format Standard
- Identifier Standard
- Imaging Standard
- Internet Protocol Standard
- Interoperability Protocol Standard
- Metadata Content Standard
- Metadata Description Standard
- Metadata Packaging Standard
- Metadata Structure Standard
- Query Language Standard
- Reference Models and Framework Standard
- Searching Protocol Standard
- Thesauri and Word List Standard
- XML DTD and Schema Standard

Deliverable D4.3 - Recommendations for Standards and Trusted Audiovisual Repositories

### 4.3 Interoperability with other standards initiatives

The beginning of Section 4 discusses the approach to the design of the Presto4U Standards Register including reference to a number of existing initiatives publishing information relating to preservation standards. The Presto4U Standards Register was not designed to be directly interoperable with other such registers although efforts have been made to learn from other initiatives and to use terminology that is widely understandable e.g. by drawing on the terminology of OAIS.

Section 9 of Presto4U Deliverable 4.4 discusses further the topic of "Alignment of Standards Register with international initiatives". One area mentioned is that of the work between the APARSEN project and Presto4U. A formal "Co-operation Agreement" was established between the APARSEN project and Presto4U specifically related to preservation standards after an observation was made that both projects were building web-based registers. This collaboration involved:

- regular discussions about activities related to preservation standards in the two projects
- sharing of ideas and early drafts of designs of the registers and their metadata schemas
- some harmonisation, where possible, of schema and taxonomy design for use in building the standards registers
- investigation into the possibilities of linking the two standards registers exposing the technical and business challenges involved

The APARSEN project partners have explained some of the benefits of the collaboration to their project in Section 2.2 of [61] and have now made the APARSEN standards register publically available [62]. Both the APARSEN and Presto4U Standards Registers present similar interfaces: tabular browsing of standards entries with filtering by a number of selectable criteria as well as a text search. As a result of the collaboration both share similar concepts that are used to categorise the standards e.g. "Domain" , "Lifecycle" and "Licence Model". However, in the Presto4U Standards Register the "domains" are the Communities of Practice which are also used in recording the level of "adoption" of standards by different communities.

It would be ideal for registers such as those developed by the Presto4U and APARSEN projects to expose their data in a machine readable format e.g. as XML documents available through a RESTful API. Such an approach would aid in the linking between standards registers and other initiatives. Initial work was conducted with APARSEN on how such an approach could allow A/V preservation standards from the Presto4U Standards Register to be listed in the APARSEN Standards Register. Although this does require some additional technical development the non-technical issues present more of a challenge:

- Data needs to be released under clear terms / licence so that other initiatives are confident in linking to it or incorporating it into their own systems

Deliverable D4.3 - Recommendations for Standards and Trusted Audiovisual Repositories

- How much data from a system such as the Presto4U Standards Register would be included in a system such as the APARSEN Standards Register? Would there just be a stub entry in the third-party system with a link to the Presto4U website to obtain the full entry? What requirements would there be on acknowledging the source of the data on the third-party system?
- Clarity is required about what access users of one system would have to data held in another system e.g. would the user need to have an account for both systems?
- What long-term commitment is made by each organisation involved to keep the data available with the agreed technical properties and terms / licence, as well as to maintain / update the data?

## 5. Use of Standards in audiovisual preservation

### 5.1 Footage Sales Libraries

Footage sales libraries and archives are generally business-oriented institutions that exploit commercially their audiovisual holdings. Digital preservation is rarely their primary goal, but it becomes necessary to let them continue exploiting their digital content in the future. The digitisation quality and file format choices are mainly driven by the clients' demand and by what the market (producers and broadcasters) is currently using.

#### **Metadata standards**

Footage sales archives are investing quite a lot to catalogue and describe in detail their footage, so that it can be easily searched and retrieved by customers in a more accurate way and in the shortest time.

Despite the importance of descriptive metadata, most of the institutions are not adopting standard metadata schemas and they are mainly using proprietary information structures implemented in internally designed database systems.

Some exceptions can be found in few broadcasters sales divisions that can use internally **EBUcore** as standard metadata schema or –for example- in the case of Istituto Luce Cinecittà that is using **EAD** (Encoded Archival Description) schema to describe its archive AV content.

Also rights metadata are not generally standardised, since common content exchange platform (B2B) are not yet in place or widely adopted. And preservation metadata are almost ignored.

#### **Format standards**

Despite the fact that **Digital Betacam** is still one of the preferred delivery format for audiovisual content, the most common file-based formats used to store and deliver content are the proprietary **ProRes** (4:2:2 both SD and HD) format from Apple and the **MPEG-4 AVC** (aka H.264) standard format, with the older **MPEG-2** (H.262) format still used in some archives.

The digitization of analogue carriers (like videotapes or film) is mostly performed for access purposes or for selling reasons rather than for optimal preservation purposes. In this domain digitization is really a customer-driven activity and often quality requirements are just those sufficient for the distribution and sale of the content.

At least, this is the case of the pure commercial footage archives (like *Getty Images*, *ITN Source*, *Sky News*, *Reuters* and *Associated Press*).

For footage archives that are also memory institutions, like Istituto Luce Cinecittà, the Imperial War Museum or British Pathé, the situation is a bit different.

For these institutions footage sales is not a core business, and long-term preservation is instead considered as an institutional mission.

In this case, long-term preservation involves mainly film collections, that are scanned and digitised in 2K or 4K quality, and the preferred file-based format for this kind of content is the ANSI/SMPTE standard **DPX** (Digital Picture Exchange), which is a still frames storage format (for the audio part the **LPCM** format in a WAV container is usually used).

The same content could be also converted for screening purposes in a Digital Cinema environment, in the **DCP** (Digital Cinema Package) format, which means basically wrapping in **MXF** files the video essences in **JPEG 2000** at 2K or 4K.

## Deliverable D4.3 - Recommendations for Standards and Trusted Audiovisual Repositories

Anyway, it should be noted that for most of these memory institutions, the preferred preservation master remains the 35mm film, which is considered safer and cheaper to preserve and handle.

### 5.2 Music & Sound Archives

The more important standards adopted by the Sound & Music community are related to audio compression. The advent of the Internet, the upgrading of the PC and the constant development of multimedia applications and platforms integrated to network services, have made this area of fundamental practical importance. Compressing an audio signal allows to minimize the amount of resources needed for encoding, thereby increasing the speed of information transmission and decreasing, consequently, the costs and the use of bandwidth. It has also brought significant benefits in storage compression, drastically reducing the cost of data storage.

Among the standards related to data compression, we must remember:

- **MPEG 1 ISO/IEC 11172-3** - The encoder has the task of taking as input an uncompressed PCM file (i.e. WAV or AIFF) and turning it into a compressed format, according to the standard MPEG encoding chosen by the user. It is an algorithm for lossy audio compression, developed by the MPEG group, which can drastically reduce the amount of data required to store a sound reproduction while remaining acceptably faithful to the uncompressed original file.

The Layer III, more commonly known as MP3, introduces new techniques in order to improve the sound quality and maintain acceptable the bit-rate.

The quality of an MP3 file depends on the encoding quality: for this reason, it makes no sense to talk about listening quality of listening in a track of 128 kbit/s or 192 kbit/s. An MP3 produced by a good encoder produces a better result than a file encoded at higher bit rates, but with a poor coder.

An important feature of the MP3 is the loss of data due to compression: thanks to the science of psychoacoustics, modern MP3 encoders algorithms make the most effective way to ensure that the sounds removed are those that cannot be detected by the human ear.

Its ubiquity has completely changed the music industry in recent years, altering the distribution of music and kicking off the phenomenon of music piracy.

- **MPEG-2 ISO/IEC 13818-3** – It is the evolution of the MPEG-1 format. From a conceptual point of view, there is nothing new compared to the previous standard. The three compression algorithms (Layer) have been improved and optimized and have been added three new sampling frequencies (16, 22.5, 24 kHz). There are also rates lower bitrates and a multi-channel encoding, primarily to meet the needs of the film industry.
- **ISO-IEC 13818-7** - The results of subjective tests have shown that the need for backwards compatibility compromises the effectiveness of the compression of the MPEG-2 encoder in terms of audio quality. Accordingly, the MPEG group has produced an addendum to the standard that specifies a method of encoding multi-channel audio, offering superior performance. This system has been standardized by ISO, and takes the name of Advanced

## Deliverable D4.3 - Recommendations for Standards and Trusted Audiovisual Repositories

Audio Coding (AAC). The AAC provides higher audio quality than MP3, for the same compression ratio. Compression at 128 kb/s roughly corresponds qualitatively to that of an MP3 at 165-175 kb/s, but the gap is reduced with increasing bitrate. It is currently used primarily by Apple in its products dedicated to audio (iTunes), in order to sell music through its online music store. There is a very similar format to AAC: it is Dolby branded (USA) and it's called AC-3. This is the currently used standard for encoding audio tracks on DVDs.

- **MPEG-4 (ISO-IEC 14496)** - This standard marks an important evolution in the MPEG world, as it introduces the concept of "object" in the Audio-Video. Basically, every media file is composed of several objects that, although they exist separately, are harmonized to achieve the overall effect. For example, in a movie you generally have voice dialogue and background music; these two "entities", having completely different physical characteristics, and can be handled by dedicated and optimized coding algorithms, one for music and the other for voice.

Among all the standards that do not address data compression, it is worth quoting at least these two concerning interoperability protocol:

- **MPEG-21 ISO / IEC 21000-2** - The MPEG standards analysed up to now, deal only with the multimedia content from a physical point of view (MPEG-1, MPEG-2, MPEG-4) and semantic (MPEG-7) while all the problems concerning the distribution of content in function of the owner (rights, copyright, etc.) are never taken into account. The standard MPEG-21 aims to solve these issues with the development of a multimedia framework providing the user with a support for the exchange, access, business, and every other type of transaction in multimedia, which is efficient, transparent and independent of the platform used.
- **AES31** - Developed by the Audio Engineering Society, the AES31 standard is an open file interchange format that was designed to overcome format incompatibility issues between different software and hardware systems. Transferred files will retain event positions, mix settings, fades, etc. AES31 makes use of Microsoft's FAT32 file system with broadcast wave as the default audio file format. This means that an AES31 file can be transferred to any DAW that supports AES31, regardless of the type of hardware and software used, as long as the workstation can read the FAT32 file system, broadcast wave, or regular wave files.

A separate chapter must be considered for any standards that concern metadata, whether they are descriptive, structural or administrative. The textual description of musical audio information it is of fundamental importance in various fields of multimedia, where the search and retrieval of information plays a primary role. Just think to the systems for music on-demand, or even to the P2P systems for downloading. In short, the indivisibility between data/information/documents and metadata is out of the question in the digital environment. More and more often in this community, digital documentation systems are unfortunately structured in a not exhaustive way. Not all the actors are willing to devote some time to a proper implementation of the descriptors. Nevertheless,

## Deliverable D4.3 - Recommendations for Standards and Trusted Audiovisual Repositories

archivists are aware that the informative value of a document is almost halved if it is separated from the context in which it was originally placed.

Referring to the standards for descriptive metadata for digital objects, it is worth mentioning:

- **DUBLIN CORE** - The Dublin Core owes its success to its simplicity on the one hand (it consists of only fifteen elements), and on the other to its extreme flexibility. Considering that even non-experts should be able to create and manage metadata, it looks like a set of metadata sufficient for an effective retrieval process. The Dublin Core metadata are easy to create, they can easily be indexed, and allowing interoperability and a greater precision compared to full text systems.
- **MPEG-7 (ISO / IEC 15938)** - The MPEG-7 standard (ISO / IEC 15938), formally called "Multimedia Content Description Interface", provides a set of tools for the description of multimedia audio-video (AV) at the symbolic and metadata level. Unlike previous MPEG standards - which had as its objective the development of compression algorithms (MPEG-1 and MPEG-2) and the organization of objects in reality heterogeneous multimedia (MPEG-4) - MPEG-7 has as ultimate end the description of the multimedia information through a textual representation (XML) which allows a simple and immediate search and navigation in relation to content, and not in terms of its physical structure (for example, a set of numbers representing the waveform or the spectrum of an audio signal).

### 5.2.1 Case Study - INA: Digitisation of audio content produced by Radio France

#### Case Study overview

This case study takes into account the digitization of the produced by Radio France, which are archived on the long-term by INA. This case is audio only content, whereas the archive are composed mostly of musical material, radio programs and shows, radio dramas, all recorded between the beginnings of the 30s until the end of the 2000s.

Some of the following sections have been presented with an interview "format", where specific questions (written in *italic style*) are provided to the preservation managers.

#### Case Study Elements

##### Digitisation

Most-used analogue sources are magnetic tapes (speed in cm/second: 76, 38, 19, 9.5, 4.75; tape width: 1/4 inch (6.25 mm), 1/2 inch (12.50 mm), 1 inch (25 mm), 2 inches (50 mm)) and direct incision 78 rpm discs (10 inches (25 cm) in diameter and about 3 minutes in length for single-sided), while the most widely used digital audio sources are DAT, but also external commissioned digital files for audio restoration. The record players used to reproduce analogue carriers are Studer 816, Studer A80, Schlumberger F462 for tapes and EMT 948 and Pierre Clement Turntables for discs.

INA's purpose regarding the quality of migration from carrier to carrier aims to have a 1:1 transposition from analogue to digital. It is mandatory that the transfers from old to new storage formats, at least in most cases, are carried out without subjective alterations, "improvements" or any "embellishments" that can distort the original content that the limited technologies of the time

### Deliverable D4.3 - Recommendations for Standards and Trusted Audiovisual Repositories

could afford. Keeping in mind the nuances of audio preservation, our aim is to provide the best possible reproduction of the audio content without losing the essence or ambience contained in an original tape recording. It is essential to transfer the entire dynamic range and frequency response of the original. It is important to understand that the intentional signal constitutes only a part of a given sound document; unintentional and unwanted artefacts (noise, distortion), caused by the technology available at the time of registration, or added later to the original signal due to improper handling (e.g. click) or by bad storage, are part also the sound file. Both must be preserved with great care, which has consequences on the choice of digital resolution. It should be noted, however, that some inaccuracies of the original recordings, such as those caused by misaligned heads in the recordings on magnetic tape (analogue or digital), could be corrected in a satisfactory manner only in the process of reproduction of the original tape. In analogue recordings on magnetic tape is common the "Azimuth error", especially if the recording equipment was not subject to regular maintenance by professional technicians. For a tape to be reproduced with the highest integrity, the playback head must be aligned at precisely the same angle to the tape and magnetic pattern as the record head that first created the signal. If the azimuth is even marginally off, the head will be unable to read the magnetic pattern properly, leading to a loss of higher frequencies upon playback. If there are multiple copies of a sound file, we select the best one for the preservation of its content. Are also required a cleaning and careful and appropriate restoration procedures, in order to optimize the recovery of the signal. The preparation of the material before it is digitized foresees specific procedures, according to the type of support that is treated each time: for 78 rpm discs, if the support allows it, subsequent readings of the disc are made in order to clean the surface by the deposition of dirt that has accumulated, which is feasible with some custom made needles passing in the grooved area; this is followed by distilled water (to avoid limestone) and soap. For tapes, we have the need to aerate and ventilate the media (making subsequent readings), because the plastic can get quite dry. It may be necessary to repair the pieces of sticky tape used for mounting, which in certain cases can reach a really large number. Lastly, Tapes are then placed inside a metal support. The equipment used for processing and playback must comply with the physical requirements of each medium. In order to minimize the risk of possible damage to the original support, the equipment for the reproduction must be maintained regularly by professional standards. Therefore, in order to diagnose problems that may arise we should be used, when available, medium for calibration in accordance with play equipment. INA has a maintenance service of the machines that takes care of this with regular intervals. On a daily basis, both the reading heads and the whole tape's path on the tape-player are cleaned, due to the deposition of dust and magnetite. If the tapes are very adhesives, even the glue could be a problem, depositing debris on the route. In the selection of procedures for cleaning and restoration we must be very careful to maintain a balance between the possibility of improving the recovery of the signal and a possible further deterioration, or even the loss of support. Therefore, in the transfer of any historical support and/or in danger, the use of the original must be maintained in any case to a minimum. The seriously deteriorated media could even be lost completely in an attempt to play them (it's the case of some damaged 78 rpm records, which reproduction and acquisition is done in one-shot); in such critical cases, it's necessary to safeguard the sound content producing a straight copy of the first (and only) playback.



## Deliverable D4.3 - Recommendations for Standards and Trusted Audiovisual Repositories

For each physical medium we create two sound files (Wave 24bit/48 kHz): one copy will be kept and stored without any treatment, while the second will be the one that will be subjected to sound restoration, always remaining pretty faithful to the original. Each restoration is a very personal task and then each operator will work in a unique and different way. Enhancement can be as simple as tape noise reduction, or as sophisticated as removing non-stationary background noise or increasing the overall range of audio sensitivity by adjusting specific frequencies in a recording. In general, we work a lot on cleaning up the signal: more or less severe Scratches, de-clipping, stationary background noise, short-duration noise pulses; compression is little or none used. It is almost always better to leave some noise in the recording than to remove a significant portion of good material. Many times, such a process merely replaces an old distortion with a new one. If a high-quality audio restoration cannot be achieved, it is often better to leave the sound material in its original state. Since human hearing easily adjusts to listening to quiet background noise or small clicks, these noises rarely prevent us from enjoying the music itself. At the same time, many listeners are annoyed by distortions in the audio material, such as the unnatural coloration of sound. The most commonly used plugins for audio restoration are: Izotope RX, Waves restoration bundle, Flux audio, Sonnox and Cedar.

### **SIP (Submission information Package)**

*During the digitisation, is it useful to produce and preserve metadata together with the created master files?*

Specific digitization metadata is produced during the process, which is registered in a local database (File maker) and then transformed in an XML file. Once the digitization ended, the file is sent to the quality control units, which do quality control on Quadriga environments to detect technical errors in the file. A final human listening test is performed to check the quality equally. The Quadriga generates an XML file that is merged with the previous XML file.

The file is then entered in the information system and within the main documentation database, as separate technical information within TOTEM.

*Is it possible to do (or do you have software that allow it) metadata enrichment through automatic content analysis (e.g. transcription)?*

The Quadriga system does an automatic check of sound quality and identifies different kinds of errors in the files (saturation, silent sections, strong differences in level)

*How are the digitized contents stored? (for example: LTO tapes, waiting to be ingested in a following phase)*

Contents are stored on LTO tapes on a robot. Two other copies are kept in different and distant locations. The ingestion is done after the quality control process is ended.

*In the last phase of digitisation, is it expected the creation of packages containing the editorial content (i.e. the master files) and the associated information?*

No, for the moment only the files are kept in the information system, and the documentation within the main documentation platform TOTEM. Technical metadata are not yet added to this main

Deliverable D4.3 - Recommendations for Standards and Trusted Audiovisual Repositories

documentation system and are kept in a specific database. The project is to migrate and fuse both databases in the future.

The following table wraps up the technologies adopted during the SIP phase.

<i>Packaging</i>	Done using a folder structure on the LTO file system.
<i>Content: Wrappers &amp; Codecs</i>	No wrappers used yet for audio files.
<i>Metadata</i>	<p>Including:</p> <ul style="list-style-type: none"> <li>● Identifiers</li> <li>● From processes such as QC, or automatic processing</li> <li>● Provenance</li> <li>● Context</li> <li>● Reference</li> <li>● Authenticity</li> <li>● Integrity</li> <li>● Fixity</li> <li>● Rights</li> <li>● Technical</li> </ul>

**Ingest**

Ingest is the phase where the packages prepared in the previous step, are checked and consolidated into the preservation system. We accept the content and all its related metadata (SIP), verify the file, extract the relevant data and prepare the AIP for storage.

*How is this step structured in your company?*

Once the quality control done, the files are ingested in the information system and associated to the documentation files.

*Who is the person in charge of taking care of the storage stage?*

A specific technical sector is in charge of the maintenance, update and migration of the files within the storage system.

*Is there a quality assurance procedure, like an automatic formal check of master files or a manual quality checking?*

Yes, explained earlier, an automatic QC is done which generates an XML report file. Within the storage system regular checksums are done in order to verify the integrity of each file.

**Archival Storage**

*How are the documents archived?*

LTO data tapes in a robot, with backup copies on shelves.

Deliverable D4.3 - Recommendations for Standards and Trusted Audiovisual Repositories

*Where exactly are the materials stored? Is the archival storage a manually administered system?*

The robotic storage system is placed within the premises of the institution. A copy of each stored file is made and kept within a Hard-disk system for browsing. A CMS (Content Management System) controls the integrity of the systems and that files are present on both systems (LTO Robot and hard disk array).

*Are tape clones (if any) stored in different geographical locations?*

LTO copies are kept on shelves on distant locations (50km away).

*Is there a "Preservation Planning", considering the policies, workflows and systems to be managed in order to preserve contents?*

Ina keeps more than a million hours of radio and television in digital files within the information system. A continuous survey, management and planning are regularly done, with fixed periods for integrity checking, migration processes and ingest of new material.

*Is there a procedure in order to check the integrity of the cloning process?*

Yes

**Access**

*Is public access and consultation performed through an internally deployed web portal of the Multimedia Catalogue?*

There are two kinds of online access: Access for professional users to the entire digitized collection at maximum quality via a specific website only accessible to identified users (1 million hours of Radio and Television). A general public website, with access to a selection of contents at a compressed rate (35 000 hours of Radio and Television). Other collections from the artistic or musical domain are also present on the websites.

**DIP storage / delivery mechanism**

Online access. Paying download for public accessible contents. Paying delivery or download for professional material after rights clearance

DIP storage / delivery mechanism Online access. Paying download for public accessible contents. Paying delivery or download for professional material after rights clearance
Access / Query Protocols (incl. security)
Finding / Search Mechanisms Specific search engines
Authenticity

## Deliverable D4.3 - Recommendations for Standards and Trusted Audiovisual Repositories

### **DIP (Dissemination information package)**

At INA we are used to create two master WAV files: the first is a preservation or archival master that replicates exactly the format and condition of the original and the second, in response to a request or an order from a consumer, is a dissemination master, that has been processed in order to improve the audio quality of the content. The OAIS supplies the object packaged as a DIP, comprising the object and relevant metadata.

The sample that we've covered in this use case is a speech documentary taken from the archives of Radio France.

The first action that has been accomplished is the removal of a distortion that is typical for vinyl, called low-frequency rumble. This distortion can be suppressed effectively by removing frequencies below 30-40 Hz from the recording. In the case of a vinyl recording, removing these frequencies does not result in a significant loss of useful musical material, especially since these frequencies are usually completely inaudible.

The second stage of the restoration is the suppression of short-duration noise pulses. They can be heard as individual clicks or crackles, and are caused by micro fissures, such as dust and dirt, on the LP's surface. We must address their removal first, before attempting to address other types of distortions; if left untouched, these clicks and crackles can negatively affect the performance of other background-noise removal algorithms. There are several types of click-removing algorithms, generally involved in two steps: The first step is the detection of click-type distortions. We identify these distortions by watching for an abrupt increase in the recording level, also known as an attack on the signal. We must have great care in choosing the appropriate working threshold on the software, because setting incorrect values will either result in many clicks left unaddressed or, on the contrary, the algorithm will also begin to modify quick attacks of sound itself. After the algorithm has detected a distortion, it attempts to correct the problem. Although different software lead to different results, the common procedure among the different algorithms is to replace the short distortion with another piece of sound of similar characteristics, interpolating data from the adjacent (good) pieces of sound. We are usually able to properly restore a distorted piece if its length does not exceed 3.0 ms.

The third and next step is the suppression of background noise distortions (usually heard as hiss, power-line noise, etc.). With speech recordings (our case examined), the easiest way to suppress stationary background noise is to remove all the frequencies that are not in the normal speech range. These include frequencies below 100-300 Hz and above 4000-5000 Hz. This method, however, is of little use in restoring music recordings. The frequency range in such recordings is very broad and is usually tightly mixed with the frequency bands of stationary background noise. In musical recordings, the most effective method to remove such distortions is the use of algorithms based on FFT (Fast Fourier Transform). These algorithms make changes directly to the frequency spectrum of the recorded sound. To perform correctly, we require isolating a sample of the noise, a part that contains the distortion, but does not contain music or speech. Once identified the location of such fragment in the recording, the algorithm analyses and saves its frequency characteristics. By doing so we subtracts the frequency characteristics of the noise sample from the frequency content of the entire recording, removing significantly the presence of stationary background noise in the

Deliverable D4.3 - Recommendations for Standards and Trusted Audiovisual Repositories

recording. In order to avoid introducing new distortions, we usually prefer not pushing too much and leaving some noise in the recording, while at the same time keeping its vividness and natural sound. Lastly, we have attenuated a stationary power-line noise, a uniform hum at 50 Hz and across multiple frequencies. We have been able to remove it using an FFT-based algorithm, although it could be removed using a notch filter, removing only very narrow frequency bands, without the addition of any significant new distortions

## Deliverable D4.3 - Recommendations for Standards and Trusted Audiovisual Repositories

### 5.2.2 Case Study - INA: Music Production, Post-Production and Electroacoustic composition

#### Case Study Overview

Music making is a well-established activity, which has been running since the invention of electric technology for composition, sound management and organization. Music making is regarded here from two points of view:

- 1) Recording of performing music, classical or popular, including instruments, special effects and sound processing
- 2) Composition of music based on independent sounds in provenance from many diverse origins, which the composer shapes and adapts to fit together within a new musical work

The procedures for constructing both types of work are very similar, and based in a well-known tool called a Sound Sequencer (among which the most known are *ProTools*, *Digital Performer*, *Nuendo*, *Cubase* or *Audacity*), which is a kind of workbench on which all elements are put together to deliver the final musical result. On a sound sequencer sounds are introduced, spliced, processed, dynamically adapted and finally mixed to a final result which is a sound file or several ones like in the 5.1 format.

Two different production components are then kept; the final Mix files, ready to be listened to, and the Sound sequencer mixing session. The sound-files are ordinary ones and are used and preserved as any sound-file is; however a totally new problem arises with mixing sessions. A mixing session is a folder with several sub-folders inside, which contain:

- A folder with the original sound-files,
- A folder with the different sound-fades produced during the mixing (a sound-fade is a specific calculation done on a section of file or files which is kept as a separate information),
- A folder with a series of analysis files necessary to process sounds, it also contains graphics of wave-forms from audio-files
- An undo folder containing the memory of all the actions done during the process
- The file containing the structure and plan of the mix

The mixing session is also dependent on the number of plug-ins contained in the Sound Sequencer; these plug-ins affect parts of files or whole tracks with specific variable settings to modify or enhance sound quality. There is also a certain amount of automation information associated to plug-ins so they will change dynamically through time. Finally a mixing session may contain MIDI (Musical Instrument Digital Interface) which is a protocol sending instructions to external machines like synthesizers or effect boxes or any kind of MIDI controlled sound generator.

Sound sequencers are used in all musical recordings (classical or popular), in electroacoustic composition and in radio program making; and cinema or television since most of them can be synchronized to image. ProTools is the professional sound sequencer for most filmmaking.

A Musical Mixing can be a highly complex ensemble of audio-files; they may range for a few superposed files (for example a musical ensemble with one microphone per instrument) to hundreds

## Deliverable D4.3 - Recommendations for Standards and Trusted Audiovisual Repositories

of sound files being played simultaneously in a session for a film. Each sound file is positioned on a track and a different control can be applied to each track (intensity, sound processing, fades...). The only relation among the tracks is the fact that they are time synchronised and can be listened to simultaneously. The Sound Sequencer creates a large number of associated files to the audio-files, containing analysis elements or specific characteristics of the mix.

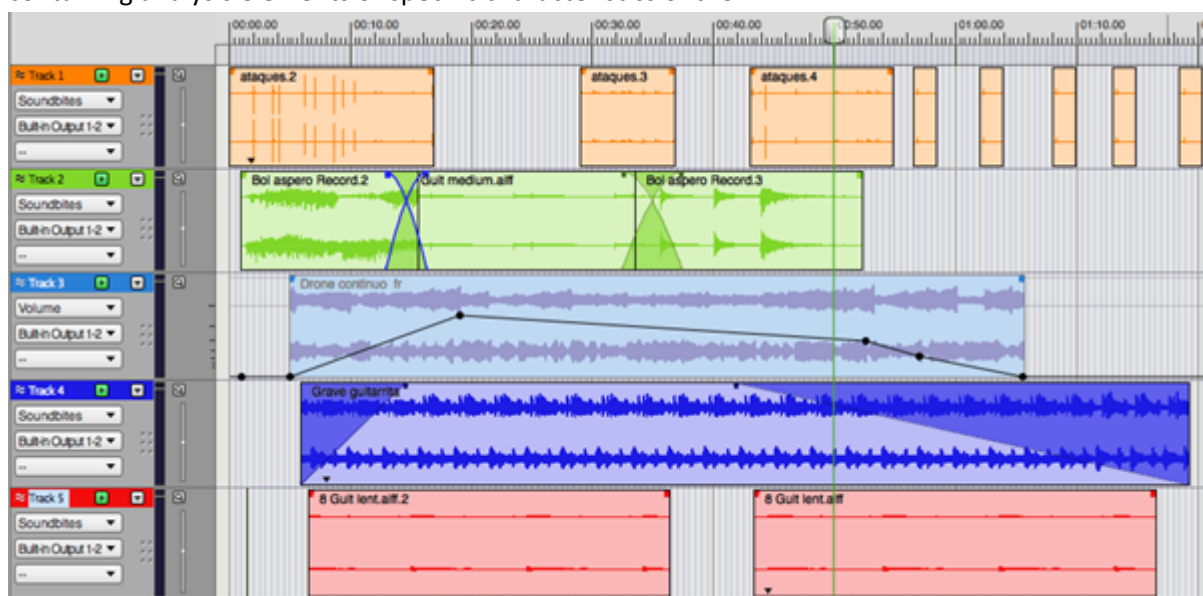

Figure 5.1: image of the mixing window of a sound sequencer. Each track contains one stereo sound. Sounds can be segmented, repeated, superposed, controlled in intensity (track 3) or with initial and ending fades (track 4). The resulting file can range from a mono file to any number of files; linked among them or separated. In this simple example with only 5 different audio-files, the software (Digital Performer) has created 59 files associated to the session.

### Case Study Elements

#### Usage of mixing sessions

Mixing sessions are environment used for recording, production and post-production; they deliver a final audio result, which is ready for use.

However several usage issues have developed in relation to mixing sessions:

- 1) Mix update: very often mixes are modified after a certain period of time for different reasons:
  - a. Some element must be changed or added
  - b. Different sub-versions need to be done (for example without a singer, longer or shorter versions)

Mixing sessions are then archived or kept accessible in order to modify them in a near future

## Deliverable D4.3 - Recommendations for Standards and Trusted Audiovisual Repositories

2) Mixing sessions are considered an archive of the work. In many production companies, the production is stored on a hard-disk and kept on a shelf as a result of a recording session

3) Remix: after some years or do to some circumstance, a work is remixed with changes on some parameters like rhythm or sound enhancement to make a new version of the same work (it may include adding new instruments or a different singer in popular).

### **Problems arising with Mixing sessions**

Mixing sessions are production environments, which have a relatively short span of life; they depend on proprietary environments (except for Audacity) and are subject to regular changes in software. However the main problem arising with the fact of reworking on mixing session is due to the fact that it is a complex array of elements with no hierarchical structure and dependent of human knowledge. To summarize the encountered problems:

1) Software incompatibility: mixing session files are proprietary files depending on a commercial software company (AVID for ProTools, MOTU for Digital Performer, Steinberg for Cubase and Nuendo) some companies have even proprietary sound formats as Sound Designer 2 (SD2). New versions and subversions are issued regularly bringing new functionalities or adapting to changes in the operating systems. The main issue here is backward compatibility, which is normally assured on a N-2 version. However if there are major breaking changes in technology, this may be shorter. Often features from a previous version are lost or not compatible with existing version.

2) Incompatibility of associated software: mixing sessions often contain plug-ins for sound processing or enhancement, these plug-ins act in real-time on the sound and the result only exist during the playback unless a specific copy of the result is done on a new audio-file. Incompatibility issues are much stronger here, mainly when plug-ins of different companies are put together on a same mixing session. Plug-ins have also settings, which are memorized, as independent files; the setting files correspond to a precise version of the plug-in. This implies that alongside with the mixing session, all the necessary plug-ins need to be kept multiplying by an important factor the risks or obsolescence. The main problem in such a complex environment is that the slightest incompatibility may result in a loss of the session for further reuse.

3) Knowledge associated to the session: Mixing sessions are done by operators knowing well the functioning of the session and having the skills of sound engineers. They construct the mixing session in function of the context, structure them on their habits and experience and establish internal hierarchy depending on the nature of the music and of the project. The operator has knowledge of the session, which belongs to him and is not transmitted except on rare occasions. When a mixing session is re-opened for some reason, if it's the same operator, he may recognize the hierarchical patterns he laid down for the session, however



### Deliverable D4.3 - Recommendations for Standards and Trusted Audiovisual Repositories

if it's a different operator, he will have to go through all the session to try to understand where sounds are regarding the final result (there is no logical distribution on the session of instruments for example, the operator may choose any structure). In many cases remixes are abandoned due to the complexity of understanding the underlying pattern of the mix.

Two different problems arise then: preserving the mixing session with all its components and preserving the logic and steps that led to it. The first is a technical preservation issue; the second one is a documentation issue.

Keeping the mixing session: As explained already, obsolescence is very quick, and the number of elements associated with the session can be huge (ranging to thousands of different files for a complex session). Different preservation issues are present here, depending on the nature of the files to preserve; however files are interlinked and often dependant, what defines more a network of files with defined interrelations more than a set of files and folders.

The preservation of resulting audio-files enters in the well-established tradition of audio preservation. The Sequencers can produce any kind of audio-format and with any kind of definition, ranging from 44,kHz to 192 kHz and from 16 bits to 32 bits. The most used output format is WAV (interleaved or des-interleaved), which is a current format for preservation.

A common interexchange framework exists among the different commercial products, called OMF or OMFI, which is an encapsulator of elements produced by a sequencer. It may contain sound or any kind of media and is used in production to assure exchange among the different Sound Sequencers. Often mixing sessions are kept as long as they are accessible, or updated manually by opening the session in a more recent version and creating an updated version. However no automatic procedures or checking is done as a preservation action. Mixing sessions may also have accompanying material as scores, sketches, plans, physical or digital, which are a part of the session and need to be preserved equally.

Keeping the associated knowledge: The knowledge related to the mixing session is kept in the operator's head. This is oral memory, subject to oblivion, modification and quick loss. In some cases hand documentation is made, but the time consumed in this operation is too long regarding production times, which tend to be short for economical reasons (it is expensive to have musicians on stage or in the studio). In other cases documentation is done after the production (if available time) but with no precise methodology in order to capture the indispensable information, which would permit a different operator to understand the logic and hierarchy of an unknown session.

Accompanying material as scores, sketches, plans, physical or digital need also to be associated to the global organization of the process.

Initiatives have been undertaken to try to structure the activity necessary to preserve a musical mixing session with the perspective of re-editing it or re-performing it. The Mustica project

## Deliverable D4.3 - Recommendations for Standards and Trusted Audiovisual Repositories

developed by several cultural institutions in 2004-2005 analysed the project and established a priority plan and methodology for any musical producer wishing to preserve their productions. From 2006 to 2009 the Caspar European analysed the problem from an OAIS perspective with a clear analysis of the phases of production.

Finally the French GAMELAN project is investigating tools that may follow the activity of an operator and permit him to easily document and hierarchize his activity.

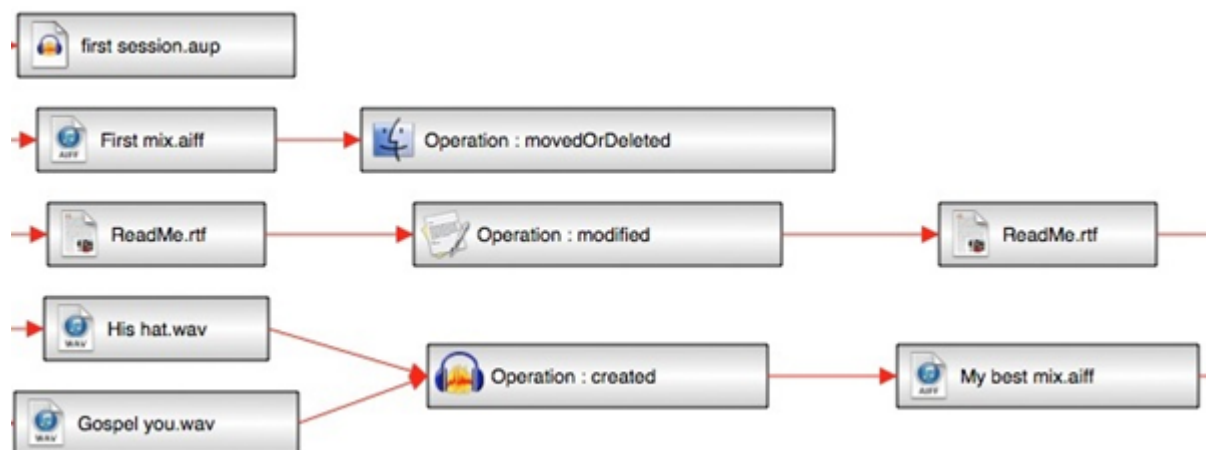

Fig 5.2: image of the File-tracker developed by the Gamelan project where a structured timeline of all the actions is kept and enriched easily by the operator.

### Digitisation

SIP (Submission information Package)

*During the digitisation, is it useful to produce and preserve metadata together with the created master files?*

Audio-files resulting from a mix are kept as such within a traditional audio preservation planning. Contents are stored in their original production format with proprietary environment (software) and sometimes file formats.

*Is it possible to do (or do you have software that allow it) metadata enrichment through automatic content analysis (e.g. transcription)?*

No, only OMF exports.

*How are the digitized contents stored? (for example: LTO tapes, waiting to be ingested in a following phase)*

Often stored on shelves as hard disks or on LTO tapes.

*In the last phase of digitisation, is it expected the creation of packages containing the editorial content (i.e. the master files) and the associated information?*

No, the most that may be done is creating OMF exchange files

## Deliverable D4.3 - Recommendations for Standards and Trusted Audiovisual Repositories

### Ingest

Mix sessions are ingested as a whole with the resulting audio-files, which represent the final musical result.

*How is this step structured in your company?*

Highly dependent on the company.

*Who is the person in charge of taking care of the storage stage?*

In many (most) cases it is the operator in charge of the process, with little time for documentation and functioning on his own memory of previous actions (not documented). In some cases there is someone in charge of organizing the collections and checking that the elements are there (more a librarian profile).

### Archival Storage

*How are the documents archived?*

Often stored on shelves as hard disks or on LTO tapes.

*Where exactly are the materials stored? Is the archival storage a manually administered system?*

Highly depends if production companies have a preservation or even conservation strategy. For large production companies, there is at least a classification strategy.

*Are tape clones (if any) stored in different geographical locations?*

Often, but not always.

*Is there a "Preservation Planning", considering the policies, workflows and systems to be managed in order to preserve contents?*

No precise preservation planning or strategy; it is mainly based in keeping objects containing files as long as they are accessible for use.

*Is there a procedure in order to check the integrity of the cloning process?*

No

### Access

*Is public access and consultation performed through an internally deployed web portal of the Multimedia Catalogue?*

Access is made through final products, mainly CDs, DVDs or online publishing of audio and audiovisual files.

## 5.3 Personal collections

Unlike professionals, people involved in the production of home videos typically have neither a specific plan nor knowledge on how to guard their digital data from loss or corruption.

Deliverable D4.3 - Recommendations for Standards and Trusted Audiovisual Repositories

Individuals and families often do not have enough skills to develop an archiving project and without education and training most of them are in the position of simply doing the best they can.

The consequence is that, naturally, the adoption of standards is not covered, simply because there is not even a reference community with which to share the practices of preservation, bringing people to act independently and often with homemade or improvised solutions.

Deliverable D4.3 - Recommendations for Standards and Trusted Audiovisual Repositories

## 5.4 Video production and Post-Production

The diversity in post-production companies and institutions affects the presence of general standards. Especially small post-production institutions – which are represented by more than 50% of the whole community - are not strategically attached to special standards. However, standards are obtained indirectly as a result of the acquisitions of software, hardware and technologies where standards are part of the concept and requirements.

In average large and medium sized post-production companies and institutions are more aware of proper use of standards especially because they are dependent of efficient workflows and functionalities regarding:

- Preservation – Metadata-tagging
- Digital Media Asset Management
- Search & Retrieve
- Exchange of assets – cooperation with other companies of media institutions or footage sales
- Metadata, file formats, wrappers, and transcoding as business drivers from content creation to delivery

### ***Metadata standards***

#### *Smaller post-production companies*

- More than 50 % of the community does not use metadata standards, tagging or similar.

#### *Small and medium sized companies*

- Around 40 % are using tagging with keywords and to some extend also descriptive metadata. However none of them are using standardised metadata schemas or automated tagging. The attempt to use metadata in the production is more based on best practices and elaborated workflows.

#### *Large companies and cooperatives / institutions*

The last part (around 10 %) – in general large and well-consolidated institutions – is in favour of using standard Digital Assets Management and Preservations systems which are based on standards. Typically metadata, descriptions, mapping and systematisation based on P/Meta 2.2, EBUcore 1.5 or DublinCore (ISO Standard 15836-2009)

Metadata in larger organisations serves as:

- Semantic Metadata functionalities stored with binaries and documents
- Rights Management capture and tagging
- Metadata as business drivers from content creation to delivery

## Deliverable D4.3 - Recommendations for Standards and Trusted Audiovisual Repositories

*Rights metadata* are not generally standardised, since common content exchange platform (B2B) are not yet in place or widely adopted.

*Preservation metadata* have until now almost been ignored, however more and more initiatives building on new products from companies like Evolpin Software or Mark Logic are trying to catch up with some of these gaps.

### **Format standards**

The most common file-based formats used to store and deliver content are the proprietary ProRes (4:2:2 both SD and HD) format from Apple and the MPEG-4 AVC standard format, with the older MPEG-2 (H.262) format still used in some archives. H.264 or MPEG-4 AVC is one of the most commonly used formats for the recording, compression, and distribution / exchange of video assets. However, MPEG-7 is also often included in new tools. It uses XML in order to store metadata and it can be attached to time code.

The digitization of analogue carriers (like videotapes or film) is mostly performed for access purposes or for distribution and selling reasons rather than for optimal preservation purposes. In this domain digitization is really a customer-driven activity and often quality requirements are just those sufficient for the distribution and sale of the content.

### **Quality Control Standards (QC)**

DPP (Digital Production Partnership – a community of broadcasters, post-production houses, video-distribution in UK) has recently specified Quality Control requirements for finished television programmes delivered as files to DPP broadcasters [63]. The document contains a list of checks for the use of distribution and exchange of video from/not from archives. The checks are divided into five groups:

- DP AS-11 compliance checks
- Automated audio checks
- Automated video checks
- Eyeball audio checks
- Eyeball video checks

Checks are mandatory and they must be passed to meet the basic delivery standards between post-production companies. If video-assets fail on one of these tests, it must be fixed before delivery to the broadcaster.

Technical warnings should be reviewed in an edit suite and fixed. Editorial warnings indicate problems which may harm viewers' enjoyment. All warnings are reviewed in an edit suite and if accepted they are noted with time codes in a QC-report.

Deliverable D4.3 - Recommendations for Standards and Trusted Audiovisual Repositories

***Standards for handling of administrative data***

There are no current standards for the administrative handling and preservation of video-assets in terms of follow up on use/reuse of assets (how many seconds, how many screenings or broadcasts), invoicing, juridical or ethical rights.

## **5.5 Film Collections and Filmmakers**

The standards employed in film preservation are based on the tradition of preserving the best achievable element in uncompressed and openly documented form. However, the community is also bound by principles of preserving the format most closely resembling the original formats of production and distribution. In analogue terms, the community tries to adopt digital equivalents to the cinematographic negative, as well as the theatrical print; since the negative represents the best original image element, while the theatrical print represents the film as it met its original viewers.

In addition to the above preservation objectives, the community also aims to take advantage of the opportunities in digital to create the most flexible masters for easy interchange and distribution, in order to both minimize cross conversion artefacts, as well as provide the most speed and cost efficient access to the film heritage and production.

The community typically addresses relatively few elements of very high cultural and financial value. Therefore data size and storage costs play less of a role than the risk of data or data quality loss. For preservation purposes the community prefers uncompressed and unencrypted options over compressed and proprietary solutions.

### **DPX (ANSI/SMPTE standard-268M-2003)**

As the default output format for many film scanners, the format remains the preservation choice of many film collections, since it contains the unaltered data of the raw scan and is well supported by subsequent post production editing and restoration suites.

### **JPEG2000 (ISO/IEC 15444-3)**

JPEG2000 is a well described and open standard, but despite many preservation benefits of the format, it is not broadly adopted, except for the use for theatrical cinema delivery, in the form of the Digital Cinema Package (DCP). The profiles for Master Archive Package (MAP) and Intermediate Archive Package (IAP) are not broadly used, even though they have been developed for the EDCINE project and are proposed as best practice by the Technical Commission of FIAF (The International Association of Film Archives). JPEG2000 remains a promising format for long term digital cinema preservation.

### **PRORES422 and PRORES4444**

ProRes is a lossy video compression format developed by Apple. It is broadly used in the production environment and is therefore both a production master format as well as an asked for delivery format for cinematographic content in post production. As a heavily proprietary format, it is regarded with some skepticism for long term preservation purposes, but is very widely adopted in modern film production.

## Deliverable D4.3 - Recommendations for Standards and Trusted Audiovisual Repositories

### **TIFF or TIF (ISO 12234-2)**

Cinematographic films can be stored as stacks of individual images in folders, typically corresponding to either the complete film or in reels. Accompanying sound is stored in separate sound files.

For metadata, The Cinematographic Works Standard has two parts:

Part I (**DIN EN 15744:2009**) A minimum set of information elements for the unambiguous identification of film works. This part of the standard can also be used for structuring human-readable output from information systems implementing the second part.

Part II (**DIN EN 15907:2010**) A specification for structuring machine-readable metadata about cinematographic works. This part of the standard can be used as a basis for data exchange between existing catalogue systems. It is also intended to serve as a guideline for information professionals seeking to build interoperable systems that carry information about moving images. Part 2 draws upon several existing standards, recommendations and reference models.

### **MPEG 1 ISO/IEC 11172-3**

The encoder has the task of taking as input an uncompressed PCM file (i.e. WAV or AIFF) and turning it into a compressed format, according to the standard MPEG encoding chosen by the user. It is an algorithm for lossy audio compression, developed by the MPEG group, which can drastically reduce the amount of data required to store a sound reproduction while remaining acceptably faithful to the uncompressed original file.

The Layer III, more commonly known as MP3, introduces new techniques in order to improve the sound quality and maintain acceptable the bit-rate.

The quality of an MP3 file depends on the encoding quality: for this reason, it makes no sense to talk about listening quality of listening in a track of 128 kbit/s or 192 kbit/s. An MP3 produced by a good encoder produces a better result than a file encoded at higher bit rates, but with a poor coder.

An important feature of the MP3 is the loss of data due to compression: thanks to the science of psychoacoustics, modern MP3 encoders algorithms make the most effective way to ensure that the sounds removed are those that cannot be detected by the human ear.

Its ubiquity has completely changed the music industry in recent years, altering the distribution of music and kicking off the phenomenon of music piracy.

### **MPEG-2 ISO/IEC 13818-3**

It is the evolution of the MPEG-1 format. From a conceptual point of view, there is nothing new compared to the previous standard. The three compression algorithms (Layer) have been improved and optimized and have been added three new sampling frequencies (16, 22.5, 24 kHz). There are also rates lower bitrates and a multi-channel encoding, primarily to meet the needs of the film industry.

### **ISO-IEC 13818-7**

The results of subjective tests have shown that the need for backwards compatibility compromises the effectiveness of the compression of the MPEG-2 encoder in terms of audio



## Deliverable D4.3 - Recommendations for Standards and Trusted Audiovisual Repositories

quality. Accordingly, the MPEG group has produced an addendum to the standard that specifies a method of encoding multi-channel audio, offering superior performance. This system has been standardized by ISO, and takes the name of Advanced Audio Coding (AAC). The AAC provides higher audio quality than MP3, for the same compression ratio. Compression at 128 kb/s roughly corresponds qualitatively to that of an MP3 at 165-175 kb/s, but the gap is reduced with increasing bitrate. It is currently used primarily by Apple in its products dedicated to audio (iTunes), in order to sell music through its online music store. There is a very similar format to AAC: it is Dolby branded (USA) and it's called AC-3. This is the currently used standard for encoding audio tracks on DVDs.

### **MPEG-4 (ISO-IEC 14496)**

This standard marks an important evolution in the MPEG world, as it introduces the concept of "object" in the Audio-Video. Basically, every media file is composed of several objects that, although they exist separately, are harmonized to achieve the overall effect. For example, in a movie you generally have voice dialogue and background music; these two "entities", having completely different physical characteristics, and can be handled by dedicated and optimized coding algorithms, one for music and the other for voice.

Among all the standards that do not address data compression, it is worth quoting at least these two concerning interoperability protocol:

### **MPEG-21 ISO / IEC 21000-2**

The MPEG standards analysed up to now, deal only with the multimedia content from a physical point of view (MPEG-1, MPEG-2, MPEG-4) and semantic (MPEG-7) while all the problems concerning the distribution of content in function of the owner (rights, copyright, etc.) are never taken into account. The standard MPEG-21 aims to solve these issues with the development of a multimedia framework providing the user with a support for the exchange, access, business, and every other type of transaction in multimedia, which is efficient, transparent and independent of the platform used.

## **5.6 Learning and Teaching Repositories**

The implementation of digital preservation guidelines in the audiovisual domain is relatively new for further and higher education institutions, so the adoption of standards is limited by the fact that this community is still trying to learn and understand how workflows should be organised in the educational domain. There is however a general agreement that the community should support and use prevailing standards recognised at a national and international level. This is also reinforced by the general mandate for higher education institutions to adopt 'best practice' guidelines recognized by the appropriate governmental authorities.

### **Format standards**

The choice of format is often dictated by the immediate need for access or storage capability and may result in loss of quality for master versions. Among the most common file-based

## Deliverable D4.3 - Recommendations for Standards and Trusted Audiovisual Repositories

video formats we find MPEG-2, MPEG-4. In some institutions we also find Motion JPEG 2000 for motion sequences of JPEG 2000 images and associated audio, based on the MP4/QuickTime format. The AAC audio coding standard is often chosen because it provides higher audio quality than MP3, for the same compression ratio.

### **Metadata Standards**

The use of metadata plays a crucial role for the discovery and accessibility of learning and teaching material and universities seem to be investing an increasing amount of time and resources in the adoption of metadata standards for the description of audiovisual resources. This is particularly true for higher education institutions that greatly rely on distance-learning activities or university libraries that have been central to the preservation of important collections in both analogue and digital format. In HE institutions with more established workflows metadata standards are considered of the utmost importance, as adherence to them will form the basis of search and discovery across the repository interface. Universities for distance-learning also use metadata standards to ensure that data is compatible with other institutions and to maintain consistency and promote best practice

Among the standards adopted in more established university archives we find MARC21, MODS, DublinCore for single resources, EAD at collection level, METS based on OAIS for submission packages and for archiving packages in the repository and PREMIS for implementing technical and administrative metadata. The use of preservation metadata is however limited to universities who have made digital preservation an institutional mandate and have a longer tradition in audiovisual archiving. In other institutions where the university library retains a more prominent role in the cataloguing of books, journals and other printed material, the description of audiovisual resources is done using the fields provided by the ISBD International Standards for Bibliographic description.

Quality control and rights management standards are not currently adopted by the community, however the ability to identify different types of rights based on the type of material and rights owners is really important for access purposes and the community would welcome adoption if resources were available.

## **5.7 Research and Scientific Collections**

The research and scientific collections community has many facets that cannot be easily summarized. First of all, we took in consideration very different research communities (e.g., linguistics, mobile web, environmental forecasting, multimedia information retrieval, math, medicine). Even if when the scientific audiovisuals are kept in a technologically advanced context, as for the multimedia information retrieval research field, all the maintainers have no mission, no legal enforcement in preserving their audiovisuals. Thus, the choice about the specific format in which the audiovisuals are maintained is rarely the result of a discussion or analysis. In most of the cases, the audiovisuals are born-digital and the original format (i.e., the format in which they have been produced or made available by others on the web) is usually maintained. Lossy compression and re-compression can have huge negative impact on repeatability of the experiments, which is the core of the scientific research, on the same data.

### Deliverable D4.3 - Recommendations for Standards and Trusted Audiovisual Repositories

Between our core experts we found the following formats: MPEG-2, HEVC, HEAACv1 (MPEG-DASH ISOBMFF), MPD, OGV, WAVE, AIFF, MP3. Regarding metadata we did not find any standard. In fact, any research field resulted to have their own needs and their own language and schemas.

Within our community, we found organizations using the OAIS model. For instance, Scuola Superiore Sant'Anna in the context of the Gra.fo project. Other initiatives like the MediaEval benchmarking, does not even consider maintaining the audiovisuals made available to the multimedia information retrieval community. In fact, each task proposer has to maintain and eventually preserve the audiovisuals used for the specific benchmarking. Each of the task proposer use specific standards for storing and metadata.

The main barriers to the adoption of standards in this community are two: first, digital preservation is not a task they have to perform, but an opportunity carried out with a best-effort approach; second, the weakness of links between members of this community is a major obstacle to the diffusion of the rare best practices.

We believe that cost-effective (at least for nonprofit organizations) solutions to the preservation of audiovisuals associated with standards would improve digital preservation of these audiovisuals. The community is ready to adopt standards but only in presence of cost-effective solutions. Moreover, efficiency of the solutions is more relevant with respect to the effectiveness.

## 5.8 TV, Radio and New Media Broadcasting

Broadcast organisations have a long tradition in formalising its production-to-archive chains. With the switch to digital production comes a resetting of paradigms. In various contexts these changes are answered with renewed attempts at standardising the process. Where for audio files the path has been cleared early on, the optimal solution for broadcast productions is under much discussion. In the field of archiving online productions, there is too much movement going on to speak of standardisation, although processes and best practices have become clear for more static forms of web communication. It's important to keep in mind that for the audiovisual archiving knowledge community, standards produce contested technological configurations – one based on technological innovation, and a frame of institutional integration [64].

In the broadcast domain the efforts by the European Broadcasting Union (EBU), whose technical recommendations several Presto4U partners work on, and thematic working groups such as the Advanced Media Workflow Association (AMWA) and the Digital Production Partnership (DPP) in the UK, who propose strategic developments and specifications for the use of MXF, are leading the way. "AS-07: MXF Archiving & Preservation" is an in-progress AMWA specification that is described in [Section 3.9](#). The Digital Production Partnership in the UK has been working on streamlining the production process from independent producers towards the larger – public and commercial – broadcasting chains, standardising not just formats but also the metadata to accompany them.

### Deliverable D4.3 - Recommendations for Standards and Trusted Audiovisual Repositories

As presented in the PrestoCentre webinar focusing on choosing a file format, making use of the wisdom of other archives' experiences is a luxury only some newly set up archival organisations in the domain have. Audiovisual institutions such as the Netherlands Institute for Sound and Vision work closely together with the production chain, where norms and standards for the broadcast MXF OP1a file also decide what's ending up in the archive. Organisations such as the KB in Sweden or Ina in France have a deposit legislation that allows them to choose their own archival format, and decided on JPEG2000 wrappers, a format that is still less used in broadcast production. A format that is gaining momentum is the FFV1 format, that has been brought into circulations by vendors such as SceneSavers (US), NOA (Austria) and organisations such as the Austrian Mediathek. The choice for a format is still undecided – and decidedly more complex – when working on the new consumer demands coming on the market – rapidly expanding resolutions growing towards Ultra-High Definition (4K) and beyond: as this contingent is growing incessantly, it will require a new set of tools and processes to work with. The list of standards contains more relevant formats, though, some of which are: MPEG-2 (ISO/IEC 13818-2), MPEG-7, AVDP, SMPTE 259M (HD-SDI), SMPTE 292M, SMPTE 377-1 (MXF), SMPTE 378M, SMPTE 379M, SMPTE 380M, SMPTE 381M, SMPTE 382M, SMPTE 384M, SMPTE 386M, SMPTE 356M-2001, AES3-IEC 60958 (AES/EBU), MPEG-4 (ISO/IEC 14496-10), MPEG-7-AVDP (ISO/IEC 15938-9:2005/Amd 1:2012).

The radio broadcasting community relies on BWA files for its production and archiving chains. Audio is subjected to more than one pass through a lossy data compression encode/decode cycle. With each additional pass the audio quality is degraded, often to an unpredictable degree. Most radio transmitters use lossy data compression for its digital transmission systems (e.g. DAB, DSAT, DTT and Internet streaming). If lossy data compression is also used during the production process it may interact, resulting in unsatisfactory audio quality as received by the listener and future users [65].

Recent quality control related standardisation activities have in their own right led to renewed standardisation and implementation into community tools. Related European research projects such as DAVID and PREFORMA contribute to this effort. The EBU released its 'periodic table of QC elements' for ingest, legacy archive transfer to files, programme delivery and programme exchange in 2014, while work is on-going on MPEG Multimedia Preservation Application Format (MP-AF).

For storage purposes, the current solutions are cross-domain: most data services make use of LTO, which is a complex carrier for smaller institutions but a cost-effective solution for the larger kind of organisation that broadcasters are. Besides the linear LTFS storage, SMPTE announced its alternative AXF format in 2014, which "provides the same functionality of LTFS while adding significant long-term archive, preservation and resiliency features" [66]. Packaging can also take place under the Bagit and METS formats, which assist in packaging metadata and objects together.

Few broadcast archives have implemented the OAIS standard into their daily practice, but implementation research is on-going, specifically with broadcast material preserving archives such as Sound and Vision and VIAA (this topic is discussed further in [Section 7](#)).

## Deliverable D4.3 - Recommendations for Standards and Trusted Audiovisual Repositories

### 5.8.1 Case Study - BBC: D3 & DigiBeta Videotape Preservation

This case study considers the file-based preservation of a selection of D3 and DigiBeta videotapes by the BBC Archive – for full details refer to [67] and [68]. The objective of this work was to produce files from the content on these videotapes rather than to build a full digital preservation repository. Therefore, the master files produced were not conceived as being part of AIPs but they may be considered as such retrospectively. This work has run over a number of years in the BBC Archive. Only the most up-to-date details / features are considered here and so they will not apply to all the file-based material that has been produced. Only those elements most relevant to this case study are considered: "Digitization", "AIPs", "Archival Storage". Elements such as "Access" are likely to become relevant at a later date as the archive collection & systems are developed.

#### Case Study Elements

##### Digitisation

Overall, the digitization from videotape to file involves numerous aspects including:

- Logistics
- Preparation of the videotapes and their metadata
- The actual digitisation of the content to master archival files including splitting multi-item recordings into separate files
- Manual Quality Checking (QC) of the files that are produced as well as some automated analysis
- Production of descriptive information including metadata, browse quality files, etc.

##### Standards & Tools

Some comments on the use of standards:

- Common broadcast standards are used e.g. for serial control of equipment, serial digital video interfaces, etc.
- Metadata about the videotapes is largely dictated by the legacy stock management system and its metadata model
- Metadata produced about the digitization process is custom designed
- The metadata produced by manual and automated QC processes mainly follows custom schemes. However, the way in which videotape recorder (VTR) faults and photosensitive epilepsy (PSE) failures are detected (and the details that are recorded about them) match industry practice.
- The browse files produced are ".mpg" (MPEG Program Stream) files containing MPEG-2 video and MPEG-1 Layer 2 audio.

Virtually all the tools used have been custom designed and built in-house to meet the specific needs of the digitisation projects.

##### AIPs

Deliverable D4.3 - Recommendations for Standards and Trusted Audiovisual Repositories

<i>Packaging</i>	The master media files are Material eXchange Format (MXF) OP1a adhering to a custom BBC Archive profile. When written to LTO tape a custom scheme is used based on TAR archive files and plain-text index files. So, each AIP is actually a combination of elements from the LTO scheme and MXF profile. Each AIP is identified by the MXF filename (held inside the TAR archive, the MXF file itself, and the LTO index file) and the MXF Unique Material IDs (UMIDs).
<i>Content: Wrappers &amp; Codecs</i>	The master media files are Material eXchange Format (MXF) OP1a adhering to a custom BBC Archive profile. They contain uncompressed audio and video essence.
<i>Metadata</i>	<ul style="list-style-type: none"> <li>● Representation Information. The LTO scheme is described in the plain text index files on the tapes themselves. The MXF profile is fully described in PDF documents – these depend on numerous other documents (e.g. MXF standards) and are not stored in the AIPs.</li> <li>● Reference Information. Includes the programme title etc. and content identifiers such as the BBC ‘programme number’.</li> <li>● Provenance &amp; Context Information. Details are included of: the original content transmission date etc.; the videotape the file was produced from; the ingest process; some details of the automated content analysis processes described above.</li> <li>● Fixity Information. Checksums (SHA-1) of the MXF files and the LTO index files are stored on the LTO tape. The MXF files contain checksums (CRC-32) per frame for each audio / video track.</li> <li>● Technical metadata. The MXF file contains standard fields describing the essential properties of the audio, video, timecode, etc.</li> </ul>

**Standards & Tools**

*SMPTE ST 377-1 “MXF File Format”*

*& related standards (ST 378, ST 379, ST 380, ST 382, ST 384, etc.)*

**Archival Storage**

The latest AIPs are currently being stored on LTO4 data tape using a custom scheme based on TAR archive files and plain-text index files. The archival storage system is manually administered and the LTO tapes are stored on shelves in vaults. The LTO tapes are cloned and a sample is checked in order to check the integrity of the cloning process. LTO tape clones are stored in different geographical locations.

**Standards & Tools**

LTO (Linear Tape Open)

Deliverable D4.3 - Recommendations for Standards and Trusted Audiovisual Repositories

### 5.8.2 Case Study - RAI: Legacy archive digitisation and preservation

#### Case Study overview

The RAI use case focuses on digital audiovisual content handled as file.

This use case should be considered provisional and will be further updated and improved during the next period (2014). These files are resulting either from digitisation of analog tape sources or from conversion to file of digital video tapes (which are not files based) or from digital born, file based content. The case of audio only content, even if present in RAI, is not treated here.

When we consider tape based content, either analog or digital, the creation of a digital AV file is named “digitisation” and the subsequent ingest to the digital AV archive will include also all the metadata related to the “digitisation process”.

An audiovisual file can be either “Master quality”, i.e. the highest available quality level, expected to be suitable for production, post-production and any re-use, or “Proxy”, i.e. usable to browse the content, preview fruition, and re-use limited to contexts in which its quality is technically acceptable.

#### Case Study Elements

##### Digitisation

Analog sources are mostly Betas am, BVU/Umatic, film 16mm, 1 inch, 2 inches for the video and quarter of inch Open Reel for audio.

Digital videotape sources are: Betacam IMX, Betacam SX, Digital Betacam, D1, D2, D5.

RAI counts a lot of Betacam like tapes (mainly SP and IMX) and most of them are in a quite good physical condition, this allowed to set up semi-automatic digitisation chains that make use of robotics and informatic systems capable to pilot all the involved devices like video recorders, digitisation boards, tape cleaners.

Digitisation plants make use of original players e.g. BVU VTR for BVU tapes, according to the format. Where possible, more recent players including on-board hardware digitisation are used, for example Betacam Analog tapes are reproduced on recent IMX VTRs that directly extract the digital version as MXF files. In any other cases specific external digitising/encoding hardware and software can be used.

The final file formats in output are MXF, with the D-10 flavour (50 Mbit/s MPEG-2 intra frame) for standard definition and HD-XDCAM (50 Mbit/s MPEG-2 long gop) for high definition.

During the digitisation, several metadata are worth to be produced and preserved together with the created master files.

Transition from AV carrier to file is delicate and prone to quality degradation and even partial content loss due to possible incorrect or not perfect reproduction in relation to the process of reading the physical media. For example the VTR heads or the tape could be dirty, the same applies for a telecinema where lenses could be dirty or out of focus.

Quality related metadata can and shall be collected, for example the measurement of levels on the heads of the VTRs that can be later analysed to discover suspicious behaviours, signalling a potential problem of the reading process. Other information collected in this phase include all the process related metadata like the date of digitisation, the id of the involved digitisation chain, the name of the operator in case of manual processing, any

Deliverable D4.3 - Recommendations for Standards and Trusted Audiovisual Repositories

found exception encountered during the operations. Despite each digitisation chain is specialised on the specific carrier, there are strong commonalities and the involved standards and tools are often shared, first of all the file formats in output are the same.

The process is quite complex and includes:

- Selection of the carriers to be digitised
- Logistics and preparation of the carriers (e.g. identification and barcode)
- The actual digitisation of the content to master files
- Derivation of a temporary proxy for preview and editorial cut
- Identification and cut of the editorial entities with generation of a single master file for each of them
- Derivation of a proxy to be delivered to the multimedia indexing system (Multimedia catalogue)
- Automatic formal check of master files and manual quality checking
- Optionally some metadata enrichment got through automatic content analysis (e.g. transcription)
- Production of packages including all the information pertaining to the editorial objects that became the objects to be preserved

The format and the properties of the proxy have changed along time. Currently it is MPEG-4 container with AVC/H264 video encoding at SD resolution and AAC audio encoding for a total bitrate at around 1Mbps.

**SIPs**

The last processing phase of digitisation is the creation of packages containing the editorial entities i.e. the master files, and the associated information. Those packages are intended to be used for ingesting into a content management system, hence they are SIPs with the point of view of OAIS, they can also considered DIPs if intended for preservation over a certain period of time. Actually and for now, those packages are only stored on LTO tapes, waiting to be ingested in a following phase when the centralised content management will be ready.

Packaging	It is for now done using a folder structure on the LTO/LTFS file system. A root folder is created for each carrier being digitised and one specific subfolder for each editorial entity emerged after the editorial cut. No standard is followed even if solution like Bagit and Mets are under evaluation.
Content: Wrappers & Codecs	The unique wrapper of choice is MXF. D-10 flavour (50 Mbit/s MPEG-2 intra frame, 625 lines, 25fps) for standard definition HD-XDCAM (50 Mbit/s MPEG-2 long gop, 25fps) for high definition.
Metadata	Mostly as custom formats either text or xml files. The metadata extracted automatically can use the MPEG-7 AVDP standard.



Deliverable D4.3 - Recommendations for Standards and Trusted Audiovisual Repositories

	<ul style="list-style-type: none"><li>● Provenance The link to the carrier/s used in the digitisation is preserved, together with possible previous format conversions (e.g. a Betacam is digitised being previously created from a BVU playout).</li><li>● Reference Includes the programme title and above all the content identifiers (used in RAI) necessary to point precisely to the content.</li><li>● Context Details are included of: the original content transmission date if applicable, information related to the ingest process, details of the automated content analysis processes.</li><li>● Fixity Checksums are calculated for each file and for each edit unit (video frame) of them.</li><li>● Integrity</li><li>● Authenticity</li><li>● Quality Includes file structure analysis results, in particular MXF structure and technical metadata in it. The manual annotations for quality use a custom based xml schema to represent the time interval where defects appear, the defect type and associated severity.</li><li>● Rights Digitised material spans several typologies with very different rights, from the internal produced content to movies just sent on air, thereby rights are also very different. This information is typically already managed in other legacy systems at tape/programme level and not considered for now in the digitisation system.</li></ul>
--	---

**Standards & Tools**

The AV standards involved for the output file formats are specifically the following from SMPTE:

SMPTE 259M “SDTV Digital Signal/Data Serial Digital Interface” and SMPTE 292M “1.5 Gb/s Signal/Data - Serial Interface”

These standards describe the well known and widely used way for serial transmission of respectively standard and high definition video in their uncompressed representation. In the RAI use case this is relevant because all digital professional devices have such kind of output (in the form of one or more BNC coaxial sockets) for the video. From these outputs is possible to easily write uncompressed raw files with dedicated boards to be configured inside IT servers, those boards just dump the bitstream on a file in the server storage. Later those files can be encoded and wrapped to finally get the format suitable for long-term

## Deliverable D4.3 - Recommendations for Standards and Trusted Audiovisual Repositories

preservation. SDI and HD-SDI can also be directly used to connect to a professional monitor and to other video devices like hardware encoders.

### SMPTE 377-1 "MXF File Format Specification"

This is the generic specification for the MXF format which is a very flexible and configurable format for the wrapper of AV files. MXF can be of very different types and can contain several audio and video tracks in many different coding as well as timecode and other metadata in a very flexible and varied way. Around this main document gravitate an entire set of connected standards with deeper details. Among them the most important for the RAI use case are SMPTE 378M "Operational Pattern 1a (Single Item, Single Package)", SMPTE 379M "MXF Generic Container", SMPTE 381M "Mapping MPEG Streams into the MXF Generic Container", SMPTE 382M "Mapping AES3 and Broadcast Wave Audio into the MXF Generic Container"

### SMPTE 386M "Mapping Type D-10 Essence Data to the MXF Generic Container"

This is the specification for the D-10 flavour of MXF files, that contains 8 audio tracks AES3 uncompressed 16 bits/sample and a single video track encoded as MPEG-2 intra-frame. The video bitrate can be 30, 40 or 50 Mbits/s. RAI decided to exclusively use 50 Mbits/s for the master quality, in that case the overall bitrate (including audio) is around 63 Mbit/s.

### SMPTE 356M-2001 "Type D-10 Stream Specifications MPEG-2 4:2:2P@ML for 525/60 and 625/50"

This standard specifies the compression constraints and bit-stream characteristics of an MPEG-2 video elementary stream operating at bit rates up to 50 Mb/s. One of the intended applications is to provide a bit stream compatible with the type D-10 format digital recorder. The video compression format defined and constrained by this standard is fully compliant with the MPEG-2 video standard (ISO/IEC 13818-2 [4:2:2P @ ML]).

### SMPTE RDD 9 "MXF Interoperability Specification of Sony MPEG Long GOP Products"

This is a registered disclosure document (not a formal standard) that specifies the commonly known as HD-XDCAM flavour of MXF, where the video is high definition MPEG-2 long gop and audio is uncompressed AES3 wrapped. The overall bitrate is 50 Mbits/s.

### MPEG-2 ISO/IEC 13818 (ITU H.222/H.262)

Is a standard for "the generic coding of moving pictures and associated audio information" that defines an entire set of encodings with lossy compression and suitable for transmission and storage. Nowadays MPEG-2 is widely used for digital terrestrial, cable and satellite television as well as inside DVDs. RAI chose this format for the preservation of the master quality content, specifically the intra-frame version at 50 Mbits/s for the standard definition and long gop always 50 Mbits/s for the high definition.

### AES3 - IEC 60958

Is a standard used for the transport of digital audio signals between professional audio devices. It is also known as AES/EBU and is published by the Audio Engineering Society

#### Deliverable D4.3 - Recommendations for Standards and Trusted Audiovisual Repositories

(AES) and as part of IEC 60958. Both D-10 and XDCAM formats convey audio tracks inside AES3 wrapping.

ISO/IEC 14496-10 – MPEG-4 Part 10, Advanced Video Coding (AVC) - ITU-T H.264

Can be viewed as a "family of standards" as it provide enough flexibility to support a wide variety of applications on a wide variety of networks and systems, including low and high bit rates, low and high resolution video, broadcast, DVD storage. In our case this format is used to generate the proxy version at standard resolution.

Concerning metadata, the systems actually do not use extensively recognised standards at least for now. The output is a collection of mainly textual files like logs from the systems, the listing of the VTRs head measurements, some xml conveying information like the date and place of digitisation, the name of the operator etc.

Metadata created include:

- reference to source material (pointer to tapes and original carriers)
- technical quality (defect annotations)
- identification information of editorial entity
- report of processes (e.g. cleaning report from the automatic cleaners)

ISO/IEC 15938-9:2005/Amd 1:2012 "Extensions to Profiles and Levels, Audiovisual Description Profile (AVDP)", 2012

The intention of MPEG-7 AudioVisual Description Profile (AVDP) is to facilitate the introduction of automatic information extraction tools in media production by providing a common format for the exchange of the metadata they generate. AVDP is a profile (i.e., subset) of the MPEG-7 Multimedia Description Interface standard, targeting applications in media production and archiving. The description tools in this profile can be used to describe the results of various kinds of media analysis such as shot/scene detection, face recognition/tracking, speech recognition, copy detection and summarization, etc. in a way that these data can be usefully integrated in media production processes. The AVDP profile supports temporal and spatial analysis of audiovisual material, including low-level audio and video descriptions. The profile defines a set of semantic constraints in order to facilitate interoperability.

#### D10SumChecker

Developed by RAI within the EU funded project PrestoPrime, it is a software component tool made available as open-source under GPL v3 licence. The tool is written in ANSI C language for use on Linux Operating systems. It provides a command line mode (from terminal) and a library which permits its integration within other software.

The MXF D10 SumChecker is intended to be used in the context of ensuring the integrity of MXF D10 Files; it computes both the checksum (current version is MD5) of the whole file, and of each edit unit. In the case of MXF D10 an edit unit is made of a single video frame and the respective audio. For each edit unit are computed the following checksums: complete edit unit, the video item of the edit unit and the audio item of the edit unit

## Deliverable D4.3 - Recommendations for Standards and Trusted Audiovisual Repositories

### MXFTechMDEextractor

It is a Java tool, distributed by RAI and developed within EU funded project PrestoPRIME (RAI/CRIT 2013). The MXF Technical Metadata Extractor is used to get out from the header of generic MXF files a core set of technical metadata which are relevant to long term preservation scenario, such as “Essence Containers”, aspect ratio, frame layout, edit rate, duration, and so on. Although it is possible to use it from command line, it is conceived for integration with other Java applications because of the simple APIs for property extraction and for getting the list of the properties the extraction of which is supported. The open source development model permits further extension of the tool.

### MXFAnalyzer

The MXF Analyser Professional (IRT, 2013) is a tool for thorough analysis and validation of MXF-files, and for easy integration of MXF analysis and validation into IT-based systems. The MXF Analyser Professional is based on the MXF::SDK developed by IRT and MOG Solutions. The full version of the analyser supports in-depth analysis of the KLV layer, Partition multiplex, Metadata (decoding and analysis), Index Tables, Essence Containers and their payload.

The total structure of the MXF file (including the contents of the Header Metadata for each partition) is exported as an instance of the XML Schema and can be further validated using XML tools.

### **Ingest**

Ingest is the phase where the SIPs prepared in the previous step, are checked and consolidated into the preservation system. All the data and information are potentially organised differently to form what is called AIP. AIP shall be structured in a way to facilitate the preservation actions (e.g. periodic integrity check) and permit the access by mean of a DIP creation to be delivered. RAI is still working on the setting up of such a preservation system that should also act as a central content management, hence also the structure and composition of the AIP is subject to variations. No other details will be given in this chapter.

### **Archival Storage**

In current systems, the storage is represented by LTO data tapes put on shelves where all the data and information are saved. Also for the future, it has been decided that at least one copy must be kept on LTO/LTFS as “master quality”.

The proxy and metadata produced, already feed the corporate indexing system called Multimedia Catalogue used for effective search and retrieve of multimedia content. The search is made through metadata (either produced manually in a full documentation process or automatically) and the system can give a preview of the audiovisual content using the available proxy. Finally the catalogue gives access to master quality files by means of references i.e. pointers to the copy preserved on LTO or a copy available on a shared online storage (also the pointer to the original carrier is kept).

### **Standards & Tools**

LTO (Linear Tape Open)

#### Deliverable D4.3 - Recommendations for Standards and Trusted Audiovisual Repositories

Originally developed in the late 1990s and continuously evolved following a published roadmap, is a data tape technology for storing large amount of data. The standard defines both the physical characteristic of the single-reel cassettes (known as Ultrium) and the way in which data must be written at low level on the tape. Current last version is LTO6 that carries up to 2,5 TB of data uncompressed. Principal LTO technology providers are Hewlett Packard, IBM and Quantum.

#### LTFS (Linear Tape File System)

Is an open format permitting the usage of LTO (Linear Tape Open) data tapes for persistent storage of generic files with almost normal file access modalities, and access latency lower than older data tape technologies. This feature is available for LTO tapes and drives since generation 5. This storage technology is a very cost effective solution for long-term preservation of large files, as it is the case for audiovisual files at master quality level. The uncompressed capacity of the single LTO tape ranges from 1.5TB for LTO5 to 2.5TB for LTO6, and the use of tape libraries allows the creation of high capacity and scalable storage systems. The use of LTFS can be seen as a protection against interoperability problems usually found with proprietary solutions.

#### LTFSArchiver

Is an open-source software service (RAI/CRIT, 2013) for handling archiving and restore of audiovisual files on Liner Tape Open (LTO) tapes, by using the Linear Tape File System (LTFS).

LTFSArchiver provides a set of HTTP services offered to client users and client applications for getting benefit from LTO/LTFS in an easier way. LTFSArchiver can be used with multiple LTO libraries and with desktop LTO drive as well. The client can register LTO tapes and assign them to “named pools”. Subsequently write requests can be posted to LTFSArchiver for single files or folder hierarchies, giving the name of target pool. Optionally LTFSArchiver can take care of computing the file checksum, which will be returned to the client together with the file locators.

In the access stage, the client can either use the same paradigm than for ingest, requesting the restore of a file or a folder hierarchy identified by its locator, or can simply request to have the tape file system mounted and available for reading.

#### Access

Access is performed through the internally deployed web portal of the Multimedia Catalogue, which provides search functionalities based on metadata produced either manually (there is an entire documentation workflow in place) or automatically (e.g. automatically transcribed newscasts). Users can be granted to access proxy in play, proxy in copy, master in copy according to their pre-defined profiles. The access to proxy in copy is possible with “Partial Restore” (a media fragment retrieved instead of the whole resource), the same is already available for master quality in a prototype and will be extended to the final production content management.

The DIP has not actually a clear and defined composition and has not a standard representation mainly for what concerning metadata. Content and metadata can sometimes

## Deliverable D4.3 - Recommendations for Standards and Trusted Audiovisual Repositories

follow different delivery path for example master files delivered on a network share and metadata delivered through e-mail.

### 5.9 Video Art Community of Practice Rights and Standards

#### Introduction

Video began to be used by artists as a medium in the mid to late 1960s. In the early 1970s their works started to enter collections of contemporary art and also to be circulated via specialist video art distributors. Today video is an established artistic medium, chosen as the primary means of expression by some of the most acclaimed artists of our day. Video artworks are held within museum and private collections as well as being distributed by bodies established for this purpose such as Electronic Arts Intermix in New York or LIMA in the Netherlands.

The focus of the core expert group for this community of practice has been the shift from digital video tape to files. Within the context of this shift, it has become clear that a range of standards are becoming increasingly relevant to this community. These include standards related to high level models for digital preservation systems such as OAIS, standards related to formats, wrappers and digital data streams and standards related to metadata.

Standardised models for digital preservation developed for a library, archive or broadcast environment often do not fit well the context of video art, particularly where works form part of a contemporary art collection. The preservation of contemporary art collections occurs during the active life of a work making the approach distinct from that of a traditional archive which have traditionally been conceived of as more static. There is scope and interest in thinking about how to model digital preservation within the contexts associated with video art, however it is unlikely that there would be a desire to establish this as a standard.

Within the museum community engaged with the preservation of video art there is less reference to standardised controlled vocabulary, ontologies and metadata schemas than one might expect. Art collections are small compared to those that exist within a library and archive and the procedures for lending and sharing collections and information about collections are different. However the demands of digital preservation, linked data and initiatives such as Europeana mean that there is a greater need and interest in standards.

With regard to metadata standards such as Dublin Core, PB-Core, PREMIS or METS it is sometimes unclear what the relationship is between a metadata schema for metadata that lives with a digital file within a repository, metadata that exists in a collection management system or other external database and also the rich body of information held in artwork records owned by different departments within the museum or collection. There is often a large amount of complex information held about a particular artwork and its components including installation specifications and exhibition histories from different moments in the life of a work, artist interviews and discussions about what is important to preserve for that particular work and critical and art historical scholarship about or related to that work. This type of information fits poorly into the confines of existing metadata schemas.

However, in contexts other than small high value collections of video artworks collected within the context of contemporary art museums, this community recognises that there are

## Deliverable D4.3 - Recommendations for Standards and Trusted Audiovisual Repositories

large bodies of works around the world that are at risk. In this context, any basic metadata is beneficial in retaining some visibility for these important histories.

### **Video Formats**

Within the community of users responsible for the preservation of video artworks, Digital Betacam has been an established archival format for a number of years. In the late 1990s the majority of major commercial galleries representing artists were aware of the need to supply those institutions collecting these works with a Digital Betacam master tape alongside any additional formats for display or access. Some artists and collecting institutions, such as Tate, also adopted uncompressed formats such as D1 and D5 as their standard archival master format. Standard preservation formats for high definition video have been more difficult to establish, although HDCAM and HDCAM SR are the most common formats supplied and collected within the high definition video tape environment.

There has been a long established distinction within this community between the formats chosen for the archival master and exhibition and access formats, with exhibition and access formats often being of a lower quality. This was in part because of the need for an artwork to be on continuous display, with 71 hours a week not being unusual as an operational requirement for busy contemporary art spaces. This meant that as soon as disc formats, such as laser disc and later DVD, were available they were widely adopted for display, despite some inevitable compromises around quality. In the adoption of file based production and delivery and the increased capacity of low cost digital playback devices that can be used within the gallery, this distinction is no longer as significant. Where there is a distinction between the exhibition format used within the gallery and the master format, a well encoded file such as h.264 nowadays offers improved playback quality than was previously available with the limited bit rates available in disc formats such as MPEG-2 encoded DVDs.

However, new risks associated with achieving consistent playback of video files have been introduced in the move from proprietary tape formats to files and from the tightly specified standardisation which comes with manufactured video tape recorders and playback hardware to software encoders and decoders.

### **Video engineering standards**

In the choices made regarding archival formats in the past, the standards governing video tape formats were understood and referenced by this community. However, it has been difficult to translate this knowledge to digital video files, where problems of inconsistent playback are beginning to emerge. Tools such as the BAVC QC tools are making it possible for those responsible for the preservation of video art to interrogate files in more detail. There is a great deal of interest in understanding and managing the software and hardware dependencies which impact consistent playback in the file based environment. A new generation of conservators with specialist knowledge of video are required to have a greater and increasing knowledge of the technical structure of the video in their collections than their predecessors were required to have when working within a tape based environment.

### **Metadata standards**

### Deliverable D4.3 - Recommendations for Standards and Trusted Audiovisual Repositories

Collection management systems such as The Museum System produced by Gallery Systems often do not explicitly reference any particular metadata standards. Of twelve institutions surveyed in 2012 none explicitly referenced any published metadata standards in the management of their video art collections (P. Falcao in 'Digital Video Preservation in Museums and Small Collections' American Institute for Conservation, Annual Meeting 2013, Electronic Media Group). However as tools developed for the library and archive community begin to be more commonly adopted, references to standards for digital preservation are becoming more common. Tools such as MediaInfo reference standards, and the community is increasingly aware of standards such as PBCORE, PREMIS and METS. Preservation tools such as Archivemata reference Dublin Core for standard descriptive metadata and also PREMIS and METS as ways of describing relationships. Many museums take a pragmatic approach whereby the technical and descriptive metadata used for the management of their collections is standardised and documented internally to support internal processes. We are also seeing an increasing awareness of the need to standardise information to support the sharing of information more broadly. For example this is clear in the work that the Museum of Modern Art is doing in New York in the development of their digital repository for digital artworks.

#### **Digital preservation standards**

With the increasing need to engage in the larger digital preservation community, standards such as OAIS (ISO 14721:2012) have begun to feature in this community, in many cases because they underpin preservation tools such as Archivemata. However because these standards are often more focused on an end of life model than an active life model they are not a perfect fit for the contemporary art environment. For this reason standards emerging from the records management community, particularly from continuum theory, may become increasingly important for this community. This is being explored in the European Funded project Pericles [69].

#### **Conclusion**

Within conservation, professional practice is more common as a reference point than internationally adopted standards. Whilst there are developments towards international standards for areas of museum governance such as environmental conditions and controls, for most areas there is less a push towards defined international standards and more a culture of emerging shared professional practice. It is clear that there are some areas, such as the standards governing the digital video formats and how they are interpreted, that are very important to this community and to the preservation of video art. The lack of standards regarding how a digital video stream is decoded by a particular player is a cause for concern. However standards relating to these areas are not seen as something that can be significantly influenced by this community. Here, the commercial interests who produce the tools for the production and consumption of video in a competitive market is rightly seen as far more powerful. However, the museum community is developing alliances with regard to the adoption and support of open source tools, for example Archivemata. One of the impacts of this is a strong culture of shared information about practice as it emerges. This lends itself well to consensus regarding decisions on implementation, for example in the



#### Deliverable D4.3 - Recommendations for Standards and Trusted Audiovisual Repositories

definition of an archival information package. It is also likely that the increased sharing of collections and information about collections will act as a driver for greater standardisation of metadata schemas, as will the requirements of funders who support digitisation efforts more broadly.

The community engaged in the conservation of video art is a small community and hence the effort required to establish international standards appropriate to this community, at least currently, is seen as disproportionate to the gains. Although there are many challenges that are specific to the video art community, opportunities do exist for collaboration with other sectors. For example, ongoing work on quality control tools and reverse-engineering of new formats would be beneficial to the wider preservation community as well as video art conservation. Sharing information and experience within and beyond the video art community will be important for the development of emerging community led practice and the ongoing preservation of digital artworks.

### **5.10 Use of Standards Case Study: ORF & MXF Overcoming Issues with complex standards**

Österreichischer Rundfunk ("Austrian Broadcasting", ORF) is the Austrian national public service broadcaster. Cube-Tec International develops integrated solutions for large media archives.

ORF had a very specific problem relating to the adoption of a standard for their digital video files which had come to light after a mass migration of files from one storage system to another was attempted. Previously ORF had digitised 23,000 hours of content for its sports department, the D10 video files that were created at the time of the digitisation project used MXF as the media file wrapper (that is the file that contains or 'wraps' both the PCM audio and D10 video elements or streams together in a single file package). When ORF began to migrate this collection of audiovisual video files they found that some of the files would not transfer. Whatever error was causing this problem was hard to find and had not been detected using the quality control tools available at the time the digitisation project was undertaken. It transpired that the system used to wrap the audiovisual contents within the MXF standard had caused the files to be encoded in such a way that they did not adhere strictly to a specific MXF shim (A shim is a constrained subset of settings within a standard - the shim is used to harmonise specific variable settings with the standard and avoid differences between files in a collection using the MXF standard that may cause interoperability issues).

The first step in rectifying the problem was to collect a group of samples and detect where the issue was coming from, the second step was to propose a solution that would maintain the integrity of the audiovisual essence. This was a most important aspect to the solution as transcoding the media stream would not have been an appropriate tactic as this could have introduced degeneration in audiovisual signal quality. These files had to be repaired without touching the media essence. In search of a solution ORF collaborated with CubeTec through the DAVID project. Both ORF and Cube-Tec have a long history of collaboration through a

Deliverable D4.3 - Recommendations for Standards and Trusted Audiovisual Repositories

range of different projects and industry associations, both are participants in the European Research project DAVID funded under the FP7 programme which began in 2013. The DAVID project addresses the challenge of how to keep audiovisual content usable over time and was set up with a strong focus on looking at damage to media, detecting its source, defining errors and looking at how these problems can be detected and avoided in audiovisual preservation workflows.

The companies proceeded through a proof of concept phase where they ringfenced the affected files within the ORF collection and defined a technical process to fix the files and make them interoperable with the new storage system and compliant with a consistent reliable version of the MXF standard. After some market research they found that that the technology could be positioned as an 'MXF Legalizer' a tool for checking the validity of MXF files and repairing them to meet industry standards. The MXF Legalizer project at ORF was the first time a repair of files had been made without having to touch the media file itself, this was a fantastic outcome as for ORF as the prospect of having to go back to re-digitise the original tape would have been a very expensive route to take. The collaboration facilitated through the support of the FP7 Project DAVID and the trust built between the parties through that project enabled Cube-Tec to develop a solution and bring the research to the wider marketplace faster and with significantly less risk.

This case study is useful in highlighting the risks in adopting standards where those standards are wide in scope and must be constrained in order to meet specific performance requirements.

## **6. Barriers to adoption of standards**

This chapter discusses the barriers that prevent or hinder users in the archiving community in adopting standards. These barriers may involve several factors, including access to documentation, administrative, legal and financial issues.

### **6.1 Lack of reference implementations**

During the process of deciding which standards to adopt relating to a specific need an organisation may seek to evaluate a number of standards and seek reference installations to understand how widespread is the adoption of a particular standard and further to this to seek information from other organisations regarding their experience of adopting a standard. The early period during which a standard is emerging is a critical stage as a standard will not gain interest within the marketplace until it has a critical mass of use cases that can be referenced to support confidence in the standard among the user group.

During the Presto4U project we have seen examples of standards being adopted by participants in collaborative projects and standards bodies at an early stage. These early adopters are critical to the success of the standard as they provide the reference points for evaluation by potential users within the community.

In order to ease the adoption of a new standard, it is mandatory to have its documentation and especially samples and reference software implementations.

The latter is mostly important especially for standards dealing with information technology and technical aspects such as file formats, because they are usually evaluated and experimented by software developers, designers and architects.

Hence the accessibility to good reference software implementation, even if they are not “engineered” and implemented just for demonstration purposes, is mandatory in order to have the adoption of the standard. In many standardization bodies it’s currently required to have a reference software implementation of the issued standard and it is responsibility of the proposer group to take care of providing the code. For example within MPEG it has been decided (during last meetings) to have a public access to reference software implementation of the issued technical standards.

Moreover where standards are adopted their application must be validated as correct, in order to do this reference tools are needed to avoid incorrect implementation that can lead to significant problems. Tools that provide a way to test in a lightweight manner the suitability or appropriateness of a standard within the context of a particular application are needed and will drive adoption.

### **6.2 Access to specification documents**

Every standardisation body is free to decide its own access policy to the documents which specify or complement their standards. Depending on such decisions by the standard

## Deliverable D4.3 - Recommendations for Standards and Trusted Audiovisual Repositories

bodies, potential adopters of standards may find difficulties in reaching the information necessary to evaluate the suitability of a standard to address their needs.

The approach of some of the most relevant standard bodies is the following.

EBU - it's not a standard body, strictly speaking, however it develops and publishes technical recommendations, technical reports, and test material [33]. With the possible exception of confidentiality related to NDA (non disclosure agreements) with manufacturers, EBU documents are in open access from the web. EBU specifications contain a text describing the terms and conditions of use, which may vary from case to case.

W3C - The standards of W3C are in open access [14] with including previous versions and working drafts.

SMPTE [97]. It's possible to browse the library of standards, making search and retrieving standard number, name, and scope/description. Access to the complete document is "restricted" to subscribers, otherwise it is proposed a "pay per standard" approach, for download on purchase; buying a single standard may be quite expensive (e.g. 250 USD for ST377-1 2011), but people interested in several/many specification will find more affordable to become subscribers.

**The item you requested requires a subscription or purchase to download.**



Full Text (PDF)  
Material Exchange Format (MXF) — File  
Format Specification  
ST 377-1:2011

To view this item, select one of the options below:

Subscribers to the SMPTE Standards Library, please [login at SMPTE.org](http://SMPTE.org) to gain access to content. If you are a SMPTE member, but do not have a Subscription to the Standards Library, please login to receive discounted pricing.

[Login at SMPTE.org](http://SMPTE.org) for Access

### Purchase Document Download

- ▶ **Pay per Standard** – You may access **this standard** by downloading it within 24 hours of purchase. SMPTE Members benefit from discounted prices.
- ▶ **Regain Access** – You can regain access to a recent Pay per Standard purchase if your access period has not yet expired.

*Figure 6.1 Example of SMPTE web site, accessing a specific standard document*

ISO/IEC - a fortuitous visitor of ISO web site [98] might get a wrong impression; the website gives free access to an index useful for search and verification of the status of published standards, including an abstract and preview. From the latter we get a notice that the great part of the document is not accessible unless buying the document; the buying basket

### Deliverable D4.3 - Recommendations for Standards and Trusted Audiovisual Repositories

functionality is active and a single pdf document may be priced for instance 158 CHF (btw the currency codes are defined by ISO 4217 and costs 158 CHF). However publicly available ISO/IEC standards exist and can be found at the URL: <http://standards.iso.org/ittf/PubliclyAvailableStandards/index.html> by the ISO/IEC Information Technology Task Force (ITTF) and the link is mentioned from abstract page of the specific standard. So some standards are publicly available, other aren't, other have parts publicly available, such as XML Schema. The last situation is the most difficult to know about, and there is the risk that the version available is not aligned with the last approved one. It's useful to know that ISO/IEC standards are available also from URL <http://www.iec.ch/standardsdev/publications/is.htm> and can be bought at exactly the same price than from [www.iso.ch](http://www.iso.ch)

ITU - Specifications published by ITU at [www.itu.int](http://www.itu.int) are available free of charge, in PDF, to the general public, provided that they are in force and final editing is complete. So in the case of twin standards, such as ISO/IEC 14496-10 and ITU-T H264, the text of the former is priced 198CHF and the latter is free of charge.

There are people and organisations who, if required, will subscribe to payment services for having their library of standard up-to-date, especially when this is strictly related to their core business, as for example the manufacturers of devices which might be sold in millions of units around the world. In other cases, a lack of access to the standard information results in the impossibility to evaluate its appropriateness for recommendation or adoption.

So if people think that knowing the details of a particular standard document is essential for their work, they will pay. Otherwise, if they are not sure, and can find free access to some alternative documentation, they will first evaluate what is available without the barrier.

When the alternative is from another standard body, the consequences are limited. As an example MPEG-21 part 17, "Fragment Identification of MPEG Resources" might address similar issues than W3C Media Fragment URI, but who can answer, without paying 158CHF for the MPEG document? Notice that the former was published in 2006 while the latter is dated 2012.

When the alternative comes from non standard initiatives, consequences can be wider, because the selection may fall on not durable solutions, that got a good dissemination for a while.

Standard bodies are getting aware of this problem and are starting taking counter-measures:

- paying more attention to standard publication package, which is not only made of a PDF document, but it very often includes normative attachments, such as XML Schema or OWL ontologies, and informative annexes, such as documentation and implementation guidelines;

## Deliverable D4.3 - Recommendations for Standards and Trusted Audiovisual Repositories

- increasing free access, reconsidering the reasons for having adopted a different policy, and increasing the number of specifications with free access to the general public;
- when they confirm restricted/pay access, at least:
  - increasing the part of descriptive information for which they provide free access
  - defining affordable policies for subscribers;
  - re-considering pricing for single documents, as they are electronic documents and prices appropriate for physical printed document are not more acceptable.

From the perspective of the communities looking at standards as potential means of addressing their needs, the possible recommendations are:

- be aware that access to some standard documents can be restricted/pay
- get informed about prices for subscriptions or more favorable access conditions
- ascertain that the information provided is complete
- get informed about work in progress and possible forthcoming amendments or newer editions
- look for alternative and complementary information sources, what you need to know might be described in other published works.

### **6.3 Implementation costs**

The decision to adhere to a standard is not without cost, and the cost can come in the form of a financial penalty, such as licensing cost, it can be in terms of the additional resources needed to implement and test a product, it could be in terms of the support needed to maintain adherence with the latest version of a standard, or it could be in terms of the time penalty of delaying availability of a product to customers. Any business looking to adopt standards will need to consider these issues carefully, and weigh them against the undoubted benefits of customer acceptance and compatibility. The following sections consider these issues in more detail.

#### **6.3.1 Licensing**

The World Wide Web Consortium (W3C) has a very clearly defined patent policy in place [94]. This policy has been introduced in the early years of W3C, in which the consortium operated only with rather use guidelines. Companies attempted to push their patented technologies into specifications in order to earn revenue from products implementing them (see e.g. [95]). This was contradicting the W3C's core goal, which is to define an open web platform accessible to all. The patent policy defines the disclosure of patents related to the standardisation work in a group, and requires royalty free licensing of the technology contributed to a specification. Clearly, this policy is a major factor for the success of W3C specifications. In order to protect the commercial interests of W3C members, the licensing is restricted to the actual specification

#### Deliverable D4.3 - Recommendations for Standards and Trusted Audiovisual Repositories

and its purpose. This point is criticised by the Free Software community, as it may limit the modification and repurposing of open source implementation of W3C specifications.

The issue of license restrictions is not generally a major issue for a product user, since any licensing costs related to the software within the product are already embedded in the price. Claims of patent ownership can, however, significantly impact the availability, compatibility or price of a product built upon a certain standard - for example the patent wrangles over JPEG and MPEG-4 have significantly affected the users and distributors of those formats at the time, although the issue revolved as much around the desirability of patenting software (which is not possible in Europe) as the enforceability of such patents. The approach taken by MPEG is to manage all licenses through the MPEG-LA (license authority), although even this did not prevent patent infringement wrangles between AT&T and Apple a few years ago. More recent standards, such as MXF, have opted for license free implementation, although this can have the disadvantage that the standard is less well defined (or contains many options to cover the needs of all vendors), and can be inconsistently applied, leading to efforts such as AMWA's AS-11 to limit the standard to a defined sub-set.

#### 6.3.2 Resources required for evaluation

The decision to adopt a standard is typically based upon a number of exercises to evaluate the appropriateness of the standard within a particular use case. This can include research and technical evaluation and testing both of which come at a cost in terms of both human and technical resources that will need to be met by the organisation seeking to adopt the standard.

Within the Audiovisual Archiving domain the decision to adopt a standard can be a very tech heavy process as many of the standards used within this industry relate to file formats for the digital encoding of media assets and the description of those assets in the form of metadata. Both file and metadata standards are highly complex in their structure and varied in their features, within the audiovisual archiving domain this is further complicated by variants of standards which can apply due to the differences in use cases arising from a Film or Broadcast Archive for example, where a standard that may suit the digital video file and information requirements for a production oriented News Archive may have no use to a Film Archive whose focus may be entirely different from an operational perspective.

In these cases the individuals analysing the appropriateness of a standard to meet their organisational needs must be able to understand the varied facets of individual standards and consider also their origins in terms of where in the sector they have originated from. This can be a time consuming process and requires investment from the organisation seeking to adopt the standard. The clearer the details and description of a standard and the narrower the scope of application lends to a more efficient analysis from the perspective of the user.

On choosing to further analyse a standard through applied testing an organisation may seek to design experiments using its own needs as a benchmark to assess the suitability of a standard.

Such analysis may include undertaking experiments which may require that the organisation have particular test data sets or infrastructure on which to perform the experiments. Access to test data sets can be a barrier to the adoption of standards within the audiovisual

Deliverable D4.3 - Recommendations for Standards and Trusted Audiovisual Repositories

archiving sector as it is often left to the organisation seeking to adopt the standard to create examples of test data and this may not be easily available to the organisation. This can apply to the adoption of standards for digital audiovisual file formats, when an organisation is designing experiments to evaluate whether a particular file format will meet their needs they will require sample test files to test functionality for file access, distribution, storage and retrieval. It seems that in the audiovisual sector test data sets are difficult to access due to the fact that the contents of the sample files (the media essence or descriptive information relating to the content) are subject to copyright and therefore cannot be distributed. This often leaves the potential adopter in a position where they must create the files internally which by default means they must have available the systems to create examples of the standard which may require investment in both hardware and software to facilitate the creation of sample files.

The requirement for hardware and software resources for evaluation of standards can also extend to significant capital infrastructure investment where file formats relating to digital preservation files for film assets are concerned. This is mainly due to the data overhead associated with digital film assets. Unlike audio files which are lightweight in terms of data displacement (and happily narrow in terms of standards for file formats) digital film files are extremely high volume data objects, even with the advances made in recent years in terms of the increase in storage capacity v footprint for various disk and tape storage formats the displacement of a film hour can run at multiple TB (TeraBytes) compared to WAV Audio at single digit GB (Gigabytes). The requirement for over 1000x the data storage and distribution infrastructure can mean that organisations who may have been archiving audio using digital processes may find themselves ill equipped to deal with even a small amount of digital film assets. In seeking to adopt a standard the availability of infrastructure may be a barrier to both the ability to assess the standard and decisions relating to further adoption.



## **6.4 Appropriateness**

This section focuses the attention to the appropriateness of standards for organisations, describing situations where only a subset of functionality covered in the standard are useful or needed, particularly in relation to metadata standards, as well as where audiovisual archives serving the needs of different sectors (for example the Film and Broadcast sectors) must consider competing standards from those sectors relating to both descriptive information or metadata and encoding standards.

### **6.4.1 Complexity or scope of standard related to need**

Over the years standards have become increasingly detailed and, more worryingly, the standards contain a great many optional implementations. Although this allows vendors more flexibility in their use of standards, it inevitably creates challenges for their customers, and can cause headaches for the vendors themselves as they try to make business decisions on how to implement a standard. This is particularly apparent in metadata standards, where some metadata fields can be used for vendor-specific data (so-called 'dark metadata'), or where a piece of metadata (such as aspect ratio flag in MXF) can appear in a number of different places in the bit stream. A generic product (such as a general purpose decoder) becomes unwieldy if it attempts to cover all the possible permutations of a standard, and the situation arises where, for example, a piece of video encoded using one encoder cannot be decoded correctly by a decoder from a different manufacturer, even though they both adhere to the same standard. In the case of MXF this has led to the creation of a simplified subset to try to ensure compatibility between vendor systems. The Advanced Media Workflow Association (AMWA) has developed AS-11, a constrained version of MXF to facilitate interoperability between equipment in the programme production chain and has more recently been working on AS-07, a vendor neutral sub-set of MXF to try to address the problem of digitised content compatibility, which is especially acute for archives.

### **6.4.2 Cross sector issues**

The Audiovisual Archiving sector covers a range of different industries and markets from organisations whose use of media is a byproduct of their core function such as educational and research archives to organisations for whom the media is central to their operations and commercial activities such as broadcasters and commercial footage libraries. This diverse range of participants is represented in the various Communities of Practice that have been assembled by the Presto4U project. While they all own and manage audiovisual objects, film or video or audio or in many cases combination of all three, their specific needs with regard to how they access, distribute and preserve their media assets can be very different and more importantly the commercial aspects that drive why they undertake certain processes and therefore the relevance of standards to those processes can differ significantly.

### Deliverable D4.3 - Recommendations for Standards and Trusted Audiovisual Repositories

The decision to adopt a standard for a Film Archive or Museum Archive may be driven by a strong preservation agenda which is deeply concerned with the creation of a digital file version of an asset which is as gentle and transparent to the original medium as possible (i.e. does not introduce any degradation to the quality of the signal through lossy compression and does not alter or colour the asset in any way), for the Film archive or Video Art Collection access to the digital asset may be extremely infrequent and this will influence the data storage model and relating standards. Conversely a Broadcast Archive will seek a standard that will support particular commercial requirements that can include ease of access, distribution and speed of retrieval. Commercial archives tend to be concerned most with a standard that will allow them to support access from multiple users (sometimes simultaneously) deliver efficiencies and high levels of interoperability to facilitate distribution and will often use compression as a means to deliver cost and operational efficiency into commercial workflows, some of these drivers are not necessarily relevant to a Film Archive. An institutional Archive such as an educational or research institute may have no need for either the 'absolute quality' requirement of the Film Archive or any of the commercial needs of the Broadcast Archive and is typically not funded to deliver either, these organisations tend to be driven by a need to preserve their archive for record but not necessarily subject to the fidelity or operational requirements of other archives and for this reason standards relating to file formats for this group can often be those used as 'proxies' by others in order to create efficiencies from both a data storage and capital budget perspective.

Where an Archive is seeking to determine which standards may suit its particular needs it can often begin by looking at the various media types contained within its archive and then look to the most prominent collections of those separate media types for direction and reference cases for what standards to adopt. In the case of a smaller institutional or educational archive this can be both a confusing and daunting process, they will typically find that there is little commonality between what standards apply to the Film and broadcast Archives and that adoption a range of standards from these diverse segments is not easily achieved. This presents a barrier to the adoption of standards as the industry is very focussed on the needs and capabilities siloed at the top end of the marketplace which is primarily populated by National Film and Broadcast collections whose resources and activities are at a scale far above many other collection in the sector. A more transversal approach to delivering standards and disseminating information regarding standards that are suitable for use cases relating to preservation of mixed format collections whose quality and commercial drivers differ could help to promote the adoption of a wider range of standards that could help these particular groups.

This also applies to metadata standards where the variance in terminology and business needs between the large market segments can vary creating complexities for smaller archives in terms of deciding what standard to adopt. While a particular metadata schema may be useful for the management of a film collection this may not apply to an oral history sound collection that contains a subset of video interviews.

## **6.5 Risks to Maturity**

The maturity of a research outcome or product is generally described in terms of its technology readiness level, where TRL-1 indicates something which is at best an undeveloped possibility, through to TRL-9, which indicates a mature product approaching the end of life. An early prototype may not conform fully with any specific standard, whilst a late stage product nearing the end of life may conform to older standards, but because of the investment needed to bring it in line with newer standards it is never updated. There are also issues to do with the maturity of the standards themselves. As we have seen, standards can take many years to ratify, and can become very complex over their lifetime, and this timescale may not be compatible with the timescale over which a product is developed and used. A new product might offer functions that are needed by a user, but it might therefore conform with a standard which is not yet stable. This leads to the problem of maintenance of the product to keep it in line with an evolving standard, whilst also meaning that, for example, files created using an early version of the product cannot be accessed using later versions of the same product, or by other similar products that conform with a later version of the standard. A similar problem can arise with older products or standards that are no longer maintained, such that backwards compatibility is lost in later implementations.

## 7. Trusted audiovisual repositories

In terms of Digital Preservation the OAIS reference model is widely accepted as providing the "theory of digital preservation" [70], defining the "conceptual blueprint" for the design and operation of a repository. The UK Data Archive [71] state that:

*"A trusted digital repository has a mission to provide reliable, long-term access to managed digital resources both now and in the future."*

and go on to say that:

*"Trust has always been critical to our relationships with depositors and users but it has increasingly become a more formal issue as standards and best practices emerge; trust is a key theme in digital preservation. "*

For example, this involves dealing properly with sensitive material or material with limited distribution / access rights, as well as ensuring that when archived material is made available at any point in the future it constitutes an authentic representation of what was originally submitted to the repository.

At least at a high level the same principles apply to all digital preservation repositories regardless of the nature of the material being preserved. A great deal of work has been done on this topic in other fields and audio-visual repositories can benefit greatly from this. A structured approach to authenticity that is specific to audio-visual content is set out in [72].

### 7.1 Standards for Repository Assessment

The OAIS document published by DPC [70] provides some thoughtful commentary on the meaning of "OAIS compliant" – a term that is often used but not normally explained – stating that:

*"Because the reference model is a conceptual framework rather than a blueprint for a concrete implementation, the meaning of OAIS-compliant is necessarily vague."*

This is one of the motivations for the development of various specifications and standards for the auditing of repositories in order to determine (and potentially certify) how "trusted" they are. The document explains that each of these specifications / standards can generally be viewed as:

*"one way of defining an OAIS-compliant archive in concrete terms, based on well-defined and measurable criteria that can be mapped to real-world repositories, organisations and systems."*

One prominent initiative to emerge from over 10 years of work in this area is the European Framework for Audit and Certification of Digital Repositories [73] [74]. This consists of three certification levels:

- Basic Certification (based on the Data Seal of Approval (DSA) [75])
- Extended Certification (self-assessment based on DSA plus self-audit based on ISO 16363 [76] or DIN 31644 [77] )

## Deliverable D4.3 - Recommendations for Standards and Trusted Audiovisual Repositories

- Formal Certification (self-assessment based on DSA plus full external audit of ISO 16363 or DIN 31644)

This allows the needs of different scales of organisation / repository to be addressed as well as offering the possibility of progression from a "Basic" through to a "Formal" certification. The European Framework for Audit and Certification of Digital Repositories provides some further background as well as the results of a study into the practicalities of implementing these approaches to repository audit. It finds that it requires "a few days' effort" for a suitably "trustworthy" digital repository to gain DSA certification and around "1.5 to 3 person months" to achieve certification against either the ISO or DIN standard.

### 7.1.1 Focus on the Data Seal of Approval

When DANS [78] was established by the two main Dutch science organizations, KNAW and NWO, they assigned it the task of developing a Seal of Approval for digital data to ensure that archived data can still be found, understood and used in the future. In 2008 the first edition of Data Seal of Approval: Quality guidelines for digital research data was presented at an international conference.



The label was initially developed for use in the Netherlands, but it was soon found to be very useful in an international context too. In 2009 the Data Seal of Approval was therefore transferred to an international body, the DSA Board, which has managed and further developed the guidelines and the peer review process ever since.

The objectives of the Data Seal of Approval are to safeguard data, to ensure high quality and to guide reliable management of data for the future without requiring the implementation of new standards, regulations or heavy investments.

The Data Seal of Approval:

- Gives researchers the assurance that their data will be stored in a reliable manner and can be reused;
- Provides funding bodies with the confidence that research data will remain available for reuse;
- Enables researchers to assess in a reliable manner the repositories that hold the data, which they want to reuse;
- Supports data repositories in the efficient archiving and distribution of data.

#### **The 16 guidelines**

The Data Seal of Approval involves 16 guidelines for applying and verifying quality aspects concerning the creation, storage, use and reuse of digital data. The guidelines have been designed with a focus on scientific materials, but they can be applied to all types of digital information. The guidelines serve as the basis for awarding the Data Seal of Approval by the DSA Board.

## Deliverable D4.3 - Recommendations for Standards and Trusted Audiovisual Repositories

The criteria for awarding the Data Seal of Approval to data repositories are in accordance with national and international guidelines for digital data archiving such as the Kriterienkatalog vertrauenswürdige digitale Langzeitarchive developed by NESTOR, the Digital Repository Audit Method Based on Risk Assessment (DRAMBORA)[79] published by the Digital Curation Centre (DCC) and DigitalPreservationEurope (DPE), and Trustworthy Repositories Audit & Certification (TRAC) [80]: Criteria and Checklist of the Research Library Group (RLG). The following publications have also been taken into account: Foundations of Modern Language Resource Archives [81] by the Max Planck Institute, and Stewardship of Digital Research Data: A Framework of Principles and Guidelines [82] by the Research Information Network.

The DSA guidelines can be seen as a minimum set distilled from the above proposals. Fundamental to the guidelines are five principles that together determine whether or not the digital data may be considered as sustainably archived:

- The data can be found on the Internet.
- The data are accessible, while taking into account relevant legislation with regard to personal information and intellectual property.
- The data are available in a usable format.
- The data are reliable.
- The data can be referred to (persistent identifiers).

These principles are integral to the guidelines, which focus on three stakeholders:

- The data producer, who is responsible for the quality of the digital data;
- The data repository, who is responsible for the quality of storage and availability of the data (data management);
- The data consumer, who is responsible for the quality of use of the data.

The basic assumption is that the data repository is responsible for enabling and supporting data producers' and data consumers' compliance with the guidelines.

A data repository is designated a Trusted Digital Repository (TDR) if it complies with Guidelines 4 to 13 and if it enables data producers and data consumers to comply with Guidelines 1 to 3 and 14 to 16.

### **Data Seal of Approval Community and Regulations**

The Data Seal of Approval is driven by the voluntary involvement of all stakeholders. The organization of the DSA is established by Regulations [83], which are available on the DSA website. The Regulations define the various rights and duties of the DSA Community.

### **DSA assessment process and online tool**

An online tool has been developed to make the DSA application process easier and more transparent. It is an online system that guides the applicant and the peer reviewer from application to awarding of the DSA.

## Deliverable D4.3 - Recommendations for Standards and Trusted Audiovisual Repositories

### **Self-assessment and peer-review process**

The starting point for obtaining the Data Seal of Approval is the website [www.datasealofapproval.org](http://www.datasealofapproval.org), where an application form can be submitted. Once the form is received by the DSA Board, a self-assessment is made available in the DSA online tool.

After the submission of the self-assessment by the data repository, the DSA Board appoints a peer reviewer who is given two months' time in which to evaluate the self-assessment. As long as a self-assessment is in the application process, it will not be made public. There is no formal site visit involved; the evaluation is done entirely through the online system. The self-assessment, including all evidence, will only be published on the websites of the DSA and the applicant data repository after the DSA has been awarded.

### **Displaying the Data Seal of Approval**

After the Data Seal of Approval is awarded by the DSA Board, the DSA logo may be displayed on the repository's website. The Board will provide appropriate HTML code, which includes the DSA logo and a link to the organization's assessment.

At the same time, the DSA Board will post the approved assessment of the new DSA repository on the DSA website, using the name of the specific repository and a logo if provided.

### **Renewing the Data Seal of Approval**

A Data Seal of Approval for a given period can be displayed indefinitely but will need to be updated periodically if the repository wants to stay compliant with newly released standards and receive the latest DSA logo. DSA-certified repositories will be contacted automatically when an update is available. The current Seal is the one issued according to version 2 of the guidelines and displaying the years 2014-2015.



Website: <http://www.datasealofapproval.org>

Contact: [info@datasealofapproval.org](mailto:info@datasealofapproval.org)

Figure 7.1: Current Seal 2014-2015

### **DSA business model**

DSA is doing well. The DSA Community is growing and thriving. Today (2014), more than 36 Seals have been awarded and nearly 35 digital archives are working on their DSA self-assessment.

The added value of the DSA process is not only recognized by individual repositories. Within the European research infrastructures, building confidence in the services offered is considered increasingly important. In this context infrastructures such and projects as CESSDA [84], CLARIN [85], DARIAH [86] and EUDAT [87] are looking at the DSA guidelines.

## Deliverable D4.3 - Recommendations for Standards and Trusted Audiovisual Repositories

At the same time, the DSA's success provides the challenge to further professionalize the DSA organization in the coming years in order to enable its community to continue to grow.

## 7.2 Case Studies

the European Framework for Audit and Certification describes a number of repositories that were involved in test audits including the Data Archiving and Networked Services (DANS) in the Netherlands and the UK Data Archive (UKDA). Lessons learned from this process are covered in the report. Further case studies relating to repository assessment or the aspiration to reach the status of "Trusted Digital Repository" are given below.

### 7.2.1 Digital Repository of Ireland (DRI) Case Study

The following case study describes the certification process followed by the Digital Repository of Ireland (DRI), an interactive national trusted digital repository for contemporary and historical, social and cultural data held by Irish institutions, providing online access, discovery and preservation.

DRI is built by a research consortium of six academic partners: Royal Irish Academy (lead institute), National University of Ireland Maynooth, Trinity College Dublin, Dublin Institute of Technology, National University of Ireland Galway, and the National College of Art and Design.

DRI considers Policy Development as central to the process of becoming a Trustworthy Digital Repository. Policies are codified decisions, a statement of Intent or a commitment. The DRI project proposal outlined the policy work-package as follows:

#### **Work Package 4. Policies and guidelines**

This will develop policies, guidelines and procedures to underpin NAVR development and implementation, recognising the diversity, commonalities and differences across HSS data, namely:

- Digital curation practices, evaluation and adoption of metadata standards with respect to Gaeilge/English language metadata, standards, media formats
- Co-ordination of work on standards and policies separately undertaken in HSS and institutional curation
- Link with key EU initiatives developing best practice and policies in digital humanities, curation and preservation e.g. DARIAH (on the ESFRI roadmap), Social science data archiving e.g. CESSDA and PLANETS (in which Microsoft actively participates)
- Develop robust policies and guidelines conforming with international best practice and Irish Law concerning protocols for data generation and preparation for archiving, language issues, documentation, preservation, copyright/intellectual property, privacy, ethics, consent, anonymisation, access, re-use rights, sharing rights, and termination.

#### **WP4 deliverables**



#### Deliverable D4.3 - Recommendations for Standards and Trusted Audiovisual Repositories

Policies and standards; Link to EU-initiatives, PLANETS, DARIAH; Best practice protocols for HSS in data generation etc. Reporting Partner: NUIM Due Date: On- going. 6-monthly reports to CMT.

Early in the project DRI adopted the Data Seal of Approval as our Policy Guideline. The Data Seal of Approval (DSA) is a "light" self-audit process that outlines 16 quality guidelines (based on OAIS) on which repositories must ensure that have policies and protocols. In framing policy, we also consult to the ISO 16363 guidelines for additional guidance, in particular we refer to the Trustworthy Repositories Audit & Certification (TRAC)[88]. TRAC is a certificate checklist which addresses organisational infrastructure, Digital Object Management and technologies, technical infrastructure and security). The ISO standard 16363 for Trusted Digital Repositories is based on the TRAC guidelines. Policies are developed via discussions conducted within a network of working groups (eg Metadata Taskforce, IP and Copyright Task Force, Data Protection Taskforce) and cross projects meetings. These policies are codified in policy statements, which are reviewed internally, and externally with reference to both national and international stakeholder advisory groups. These frameworks have allowed us to develop both our policies and our infrastructures in a robust and coherent manner.

#### 7.2.2 B&G / "Sound and Vision" - "OAIS Compliant Preservation Workflows in an AV Archive"

The authors of "OAIS Compliant Preservation workflows in an AV archive: a requirement projects" [89] describe the Netherlands Institute for Sound and Vision (Beeld en Geluid) as being "responsible for storing and providing access to broadcasted television and radio programs" and functioning "as the Dutch national audiovisual archive". The report states their aspiration "to become a 'trustworthy digital repository' for Dutch audiovisual cultural heritage collections" and details the work on a project to define the requirements that needed to be met in order to achieve this.

Some of the key messages from the report and learning points for Sound and Vision include:

- Involving the whole organisation. Recognition of the importance of involving the entire organisation in "digital lifecycle management decision making" and ensuring that the organisation as a whole has digital preservation knowledge or at least awareness.
- Strategies, processes and workflows. Identifying that in addition to designs for metadata dictionaries and archival objects etc it is crucial to develop strategies, processes and workflows to ensure trusted preservation. For example, the report highlights how studying OAIS helped to make more explicit the "important relationship the archive has with its producers/donors as well with its Designated Communities" and therefore the need to negotiate and document an archive Submission Agreement.
- Requirements not all met by one system. The authors recommend that "different requirements be fulfilled by different components within the total Enterprise IT architecture". They also identify the challenge involved in deciding whether a

#### Deliverable D4.3 - Recommendations for Standards and Trusted Audiovisual Repositories

preservation requirement is best met by technical implementations or workflow designs.

- Preservation business processes require further development. The future development of the business processes surrounding preservation are identified as one area for further work. For example, one question identified is around whether different preservation levels should be used for broadcast production material and cultural heritage material.

Based on the achievements of the project the report states Sound and Vision's plan "to seek a sort of certification for digital archives, the so-called Data Seal of Approval" and notes that many of the policy documents etc developed during the project could be used as evidence during the Data Seal of Approval assessment process.

#### 7.2.3 Digital Production Partnership - "10 Things You Need to Know About Digital Storage"

The Digital Production Partnership is a partnership of the main broadcasters in the UK who are working to smooth the transition to file-based production and programme delivery through a programme of technical and non-technical activities. In September 2014 the DPP published a report titled "10 Things You Need to Know About Digital Storage" [90] – an introductory guide to the "archiving" of file-based media assets. This recognises that many programme production teams etc do not have digital archives or even any basic strategy for archiving file-based content. This audience is not likely to be aware even of the basics of digital preservation and certainly will be a long way from considering the need for a Trusted Digital Repository.

Each of the ten chapters answers a question like: "Why store my media?"; "What should I keep?"; "How will I know it's safe?"; "How can I stop the wrong people from getting in?". The document then concludes with a one page checklist consisting of ten questions which readers can use to simply assess whether or not they have considered each of the key aspects covered in the document when planning their "archive" solution. Clearly an organisation that considers all the areas listed does not necessarily have a comprehensive digital preservation solution nor could anyone assert that it is a Trusted Digital Repository. However, this does appear to be an extremely useful document for the target audience that helps readers to begin the journey towards such a repository.

### 7.3 Conclusions

A number of standards have been developed for appraisal and certification of the "trustworthiness" of digital repositories and carrying out audits or self assessments against these has been shown to be practical. Even without any assessment being carried out these standards appear to be driving development of good practice in organisations with more developed digital preservation repositories.

Deliverable D4.3 - Recommendations for Standards and Trusted Audiovisual Repositories

A lot of this progress on Trusted Digital Repositories has been made in relation to non audio-visual content – it is important for all the audio-visual Communities of Practice to learn from this progress. For this to be possible, as well as awareness of this work on Trusted Digital Repositories, simpler guidance is required in order help organisations get started. The DPP report entitled "10 Things You Need to Know About Digital Storage" [90] is a good example of this. Ideally an organisation would then understand how to progress, if appropriate, to more sophisticated preservation practices perhaps ultimately achieving "Formal Certification" under the European Framework for Audit and Certification of Digital Repositories. The work on "Levels of Digital Preservation" [91] and the "Digital Preservation Maturity Model" [92] are useful here as another way of understanding the different degrees of digital preservation competence and a possible roadmap for progression.

## 8. Conclusion

The document has described the main aspects (issues, strengths and weaknesses) to take care when dealing with the relevant and newborn standards in the field of audiovisual preservation. Moreover a quick view of trusted audiovisual repositories has been provided. Standards have been reported with great details and latest updates, exploiting the involvement in writing of the several experts being either member of the Presto4U projects or the standardization bodies issuing few of them.

Selected use cases from the Presto4U Communities of Practice have been reported, together with an analysis of current use of standards and technologies, the potential barriers against their adoption as well as potential issues that specific standards can imply in the digital preservation perspective (for example the lack of supporting communities).

From the use cases collected among CoPs, we can summarize that professional practices are considered as “references”, more than any other standards or specifications. This is all the more true within conservation communities, whilst in other CoPs such as Broadcasters or Film makers, many choices are driven by professional technologies available on the global marketplace (as simple example we can cite BetaCam and D10 among others introduced by Sony).

Best practices and technologies imposed by the world of trades are what CoPs are looking at when asked to select formats and evaluate preservation strategies.

Beyond doubt there is a lack of standards among digital preservation, especially (but not only) for what concerns preservation metadata description information. In order to fill in this gap it worths mention the standard created specifically for describing preservation audiovisual metadata, the MP-AF [93], because has been successfully supported by the Presto4U project. Unfortunately the needed time for issuing new standards is usually longer than the average project lifetime: MP-AF started as Proposal submitted to ISO on mid 2011 and will have the official Draft International Standard assignment on February 2015. However that doesn't mean that CoPs have to give up to collaborate and propose novel standards: whenever CoPs have come up with new formats, practice or process flow that can be shared and could be valuable to other, they have to seriously think about submit it to an appropriate standardization body. If they do not have the needed skill or resources for writing and supporting the proposition, they must be aware that every standardization body is made up of specific working groups dealing with a specific standard, that are more than welcome to get suggestions and novel ideas from everybody, all the more true from accredited and professional CoPs.

In order to provide the CoPs with a simple access to latest updates on audiovisual standards, the Presto4U published at the PrestoCentre website a standard register, described in this report in a dedicated chapter.

Good practices are also driving the appraisal and certification of trustworthiness of digital repositories, even if no specific guidelines are available for audiovisual collections. DSA has been reported in the document as a simple practice for assessing every kind of digital repository.

Deliverable D4.3 - Recommendations for Standards and Trusted Audiovisual Repositories

## Glossary

Due to the several technical details described in the document, in the following has been reported the list of acronyms and terms used and mentioned in the text. It's not exhaustive.

AAC	Advanced Audio Coding
AAF	Advanced Authoring Format
AES	Audio Engineering Society
AIP	Archival Information Package (OAIS)
AMWA	Advanced Media Workflow Association (MXF)
ANSI	American National Standards Institute
API	Application Programming Interface
AV	Audio Visual
AVC	Advanced Video Coding (MPEG-4)
AVDP	AudioVisual Description Profile (MPEG-7 part 9, ISO/IEC 15938-9:2005/Amd.1)
AVI	Audio Video Interleave (AV wrapper)
AXF	Archive eXchange Format
BNF	Bayonet Neill–Concelman, a quick connect/disconnect RF connector
BPEL	Business Process Execution Language
BPMN	Business Process Model and Notation
CCSDS	The Consultative Committee for Space Data Systems
CD	Compact Disk
CDMI	Cloud Data Management Interface
CMS	Content Management System
CoP	Community of Practice
CRC	Cyclic Redundancy Check (checksum algorithm)
DC	Dublin Core
DCC	Digital Curation Centre
DID	Digital Item Declaration (MPEG-21)
DIP	Dissemination Information Package (OAIS)
DPC	Digital Preservation Coalition
DASH	Dynamic Adaptive Streaming over HTTP
DAT	Digital Audio Tape
DDS	Digital Data Storage
DIN	Deutsches Institut für Normung
DS	DuraSpace
DSA	Data Seal of Approval
DV	Digital Video
DVCAM	Sony professional version of DV
DVD	Digital Versatile Disc (video)
EBU	European Broadcasting Union
EDM	Europeana Data Model
EXIF	EXchangeable Image file Format
FFT	Fast Fourier Transform

Deliverable D4.3 - Recommendations for Standards and Trusted Audiovisual Repositories

FIMS	Framework for Interoperable Media Services (EBU)
FTP	File Transmission Protocol
FFT	Fast Fourier Transform
FPS	Frame Per Second
FS	File System
GDFR	Global Digital Format Registry
GNU	recursive acronym for "GNU's Not Unix!", a Unix-like OS
GoP	Group of Picture (video format)
GPL	GNU General Public License
HD	High Definition (video)
HDFS	Hadoop Distributed File System (Apache)
HEVC	High Efficiency Video Coding (MPEG-H)
HSM	Hierarchical Storage Management
HTTP	HyperText Transfer Protocol
IASA	International Association of Sound and Audiovisual Archives
IEC	International Electrotechnical Commission
ISO	International Organization for Standardization
ITU-T	International Telecommunication Union – Telecommunication (Standardization Bureau)
JPEG	Joint Photographic Experts Group
JSON	JavaScript Object Notation
JTC	Joint Technical Committee (standardization body structure)
KLV	Key Length Value
LoC	Library of Congress
LTFS	Linear Tape File System
LTO	Linear Tape Open
MCO	Media Contract Ontology
METS	Metadata Encoding and Transmission Standard
MODS	Metadata Object Description Schema (LoC)
MOM	Message Oriented Middleware
MP-AF	Multimedia Preservation - Application Format (MPEG-A part 15, ISO/IEC 23000-15)
MPEG	Moving Picture Expert Group
MXF	Material eXchange Format
NA	National Archives (UK)
NIST	National Institute of Standards and Technology
NoE	Network of Excellence
NTSC	National Television System Committee (video-24fps)
OAI-PMH	Open Archives Initiative - Protocol for Metadata Harvesting
OAIS	Open Archival Information System
OASIS	Organization for the Advancement of Structured Information Standards
OMG	Object Management Group
OWL	Web Ontology Language
OP	Operational Pattern (es. MXF-OP1A)

Deliverable D4.3 - Recommendations for Standards and Trusted Audiovisual Repositories

OS	Operating System
PA-AF	Professional Archival -Application Format (MPEG-A part 6, ISO/IEC 23000-6)
PAL	Phase Alternating Line (video-25fps)
PCM	Pulse-code modulation (audio coding)
PDF	Portable Document Format
PREMIS	PREservation Metadata: Implementation Strategies
PSE	PhotoSensitive Epilepsy
P4	Presto Prime Preservation Platform
P4U	Presto4U
QA	Quality Analysis
QC	Quality Control (or Check sometimes)
RDF	Resource Description Framework
REST	Representational State Transfer
SD	Standard Definition (video)
SDI	Serial Digital Interface
SDK	Software Development Kit
SHA	Secure Hash Standard - Cryptographic algorithm
SIP	Submission Information Package (OAIS)
SMPTE	Society of Motion Picture and Television Engineers
SNIA	Storage Networking Industry Association
SOAP	Simple Object Access Protocol (distributed objects)
SPARQL	recursive acronym for Protocol And Rdf Query Language
TAR	Tape ARchive (archive software tool and command)
TOGAF	The Open Group Architecture Framework
TMS	The Management System (CMS widely used among Museums and Art Galleries)
UDFR	Unified Digital Format Registry
UMID	Unique Material IDentifier
UML	Unified Modelling Language
UUID	Universally Unique IDentifier
VTR	Video Tape Recorder
W3C	World Wide Web Consortium
WG	Working Group (standardization structure)
XDCAM	series of products for digital recording (introduced by Sony in 2003)
XML	eXtensible Markup Language

## References

- [1] Encyclopedia Britannica - Definition of Standard  
<http://www.britannica.com/EBchecked/topic/563034/standardization>, Last accessed: 31/12/2014
- [2] Wikipedia - Definition of Technical Standard  
[http://en.wikipedia.org/wiki/Technical\\_standard](http://en.wikipedia.org/wiki/Technical_standard) Last accessed:
- [3] Library of Congress - Definition of Standard - <http://www.loc.gov/standards/> and <http://www.loc.gov/rr/scitech/trs/trswhatare.html> - Last accessed: 31/12/2014
- [4] 'Working in Standards is like working in real life' presentation by L. Chiariglione, Definition of Standards [http://docbox.etsi.org/Workshop/2013/201306\\_WSC/Presentations/1-1%20WSC2013%20Chiariglione%20CEDEOnet.pdf](http://docbox.etsi.org/Workshop/2013/201306_WSC/Presentations/1-1%20WSC2013%20Chiariglione%20CEDEOnet.pdf) - Last accessed: 31/12/2014
- [5] Reference for Standard by NIST - [www.nist.org](http://www.nist.org) - Last accessed: 31/12/2014
- [6] The ABC's of Standards Activities [http://gsi.nist.gov/global/docs/pubs/NISTIR\\_7614.pdf](http://gsi.nist.gov/global/docs/pubs/NISTIR_7614.pdf) - Last accessed: 31/12/2014
- [7] REFERENCE MODEL FOR AN OPEN ARCHIVAL INFORMATION SYSTEM (OAIS) RECOMMENDED PRACTICE CCSDS 650.0-M-2 - MAGENTA BOOK June 2012
- [8] CCSDS - <http://public.ccsds.org/default.aspx> - Last accessed: 31/12/2014
- [9] Library of Congress - Standards - <http://www.loc.gov> - Last accessed: 31/12/2014
- [10] MODS - <http://www.loc.gov/standards/mods/> - Last accessed: 31/12/2014
- [11] METS <http://www.loc.gov/standards/mets/> - Last accessed: 15/12 2014
- [12] PREMIS - <http://www.loc.gov/standards/premis/> - Last accessed: 15/12 2014
- [13] W3C <http://www.w3.org> - Last accessed: 31/12/2014
- [14] W3C - Standards - <http://www.w3.org/standards/> - Last accessed: 31/12/2014
- [15] MPEG within the ISO structure, L. Chiariglione <http://mpeg.chiariglione.org> - Last accessed: 31/12/2014
- [16] PREMIS Data Dictionary for Preservation Metadata -



Deliverable D4.3 - Recommendations for Standards and Trusted Audiovisual Repositories

<http://www.loc.gov/standards/premis> Last accessed: 31/12/2014

[17] Library of Congress Linked Data Service: Preservation Metadata: Implementation Strategies (PREMIS) Ontology - <http://id.loc.gov/ontologies/premis.html> Last accessed: 31/12/2014

[18] Library of Congress Linked Data Service: Preservation vocabularies - <http://id.loc.gov/vocabulary/preservation> - Last accessed: 31/12/2014

[19] EBU Core Metadata Set - <https://tech.ebu.ch/MetadataEbuCore> - Last accessed: 31/12/2014

[20] PB Core: Public Broadcasting Metadata Dictionary Project - <http://pbcore.org> - Last accessed: 31/12/2014

[21] SMPTE Metadata Registries and Related Items - <http://www.smpte-ra.org/mdd/> - Last accessed: 31/12/2014

[22] Audio Engineering Society. AES standards - <http://www.aes.org/standards/> - Last accessed: 31/12/2014

[23] AudioMD and VideoMD: Technical Metadata for Audio and Video - <http://www.loc.gov/standards/amdvmd/> - Last accessed: 31/12/2014

[24] Metadata Encoding and Transmission Standard Official Web site - <http://www.loc.gov/standards/mets/> - Last accessed: 31/12/2014

[25] Van Garderen, P. 2010. Archivematica: Using micro-services and open-source software to deliver a comprehensive digital curation solution, iPres2010 Conference.

[26] MCO <http://vroddon.sdf-eu.org/mco/mco-core/> - Last accessed: 31/12/2014

[27] Extensions for MPEG-21 CEL (Contract Expression Language) and MCO (Media Contract Ontology) based on PSAF (Publish/Subscribe Application Format), J. Delgado, L. Boch, S.Llorente, A. Di Carlo, V. Rodríguez-Doncel. Document m35068 in input to MPEG110th meeting, October 2014.

[28] Paul Groth, Luc Moreau (eds.), PROV-Overview: An Overview of the PROV Family of Documents, W3C Working Group Note, April 2013, <http://www.w3.org/TR/prov-overview/> - Last accessed: 31/12/2014

[29] Timothy Lebo, Satya Sahoo, Deborah McGuinness (eds.), PROV-O: The PROV Ontology, W3C Recommendation, April 2013, <http://www.w3.org/TR/prov-o/> - Last accessed: 31/12/2014

Deliverable D4.3 - Recommendations for Standards and Trusted Audiovisual Repositories

- [30] Web Annotation Working Group, <http://www.w3.org/2014/annotation/charter/> Last accessed: 31/12/2014
- [31] Bernhard Haslhofer, Robert Sanderson, Rainer Simon, and Herbert van den Sompel. Open annotations on multimedia web resources. Multimedia Tools and Applications, pages 1–21, 2012.
- [32] Robert Sanderson, Paolo Ciccarese, and Herbert Van de Sompel. Open annotation data model. <http://www.openannotation.org/spec/core/>, 2013 - Last accessed: 31/12/2014
- [33] EBU Technology & Innovation, <https://tech.ebu.ch/> Last accessed: 31/12/2014
- [34] FIMS, <http://www.fims.tv/> - Last accessed: 31/12/2014
- [35] AMWA <http://www.amwa.tv/projects.shtml> - Last accessed: 31/12/2014
- [36] Application Specification 07, <http://www.amwa.tv/projects/AS-07.shtml> - Last accessed: 31/12/2014
- [37] Federal Agencies Digitization Guidelines Initiative Audio-Visual Working Group [http://www.digitizationguidelines.gov/guidelines/MXF\\_app\\_spec.html](http://www.digitizationguidelines.gov/guidelines/MXF_app_spec.html) - Last accessed: 31/12/2014
- [38] APARSEN <http://www.alliancepermanentaccess.org/index.php/aparsen/> - Last accessed: 31/12/2014
- [39] European standardisation guidelines, standardisation policies and rules <http://ec.europa.eu/enterprise/policies/european-standards/documents/official-documents/> - Last accessed: 31/12/2014
- [40] Digital Curation Centre Standards Register & Standards Framework - <http://www.dcc.ac.uk/resources/standards> - Last accessed: 31/12/2014
- [41] Nestor list of standards [http://www.langzeitarchivierung.de/Subsites/nestor/EN/Standardisation/standardisierung\\_no\\_de.html](http://www.langzeitarchivierung.de/Subsites/nestor/EN/Standardisation/standardisierung_no_de.html) - Last accessed: 31/12/2014
- [42] Library of Congress, <http://www.loc.gov/standards/> Last accessed: 31/12/2014
- [43] Digital Preservation Coalition, <http://www.dpconline.org/advice/preservationhandbook/media-and-formats/file-format-and-standards> - Last accessed: 31/12/2014
- [44] Audio Engineering Society standards, <http://www.aes.org/standards/> - Last accessed: 31/12/2014

Deliverable D4.3 - Recommendations for Standards and Trusted Audiovisual Repositories

- [45] JISC Metadata standards and interoperability, <http://www.jiscdigitalmedia.ac.uk/guide/metadata-standards-and-interoperability> - Last accessed: 31/12/2014
- [46] SAA External digitisation standards, <http://www2.archivists.org/standards/external/123> - Last accessed: 31/12/2014
- [47] METS, <https://www.prestocentre.org/standards/mets/1.10> - Last accessed: 31/12/2014
- [48] AudioMD, <https://www.prestocentre.org/standards/audiomd/2.0> - Last accessed: 31/12/2014
- [49] Presto Centre, <https://www.prestocentre.org/> - Last accessed: 31/12/2014
- [50] METS <http://www.loc.gov/standards/mets/> - Last accessed: 15/12 2014
- [51] METS, Presto4U, Standards Register, <https://www.prestocentre.org/standards/mets/1.10> - Last accessed: 15/12 2014
- [52] MARC21, Standards Register, <https://www.prestocentre.org/standards/marc-21/update-no.-17> - Last accessed: 15/12 2014
- [53] METS, <https://www.prestocentre.org/standards/mets/1.10> - Last accessed: 15/12 2014
- [54] OAIS, <https://www.prestocentre.org/standards/oais/iso-14721> - Last accessed: 15/12 2014
- [55] Bagit, <https://www.prestocentre.org/standards/bagit/0.97> - Last accessed: 15/12 2014
- [56] SMPTE 377-1 MXF File Format Specification, <https://www.prestocentre.org/standards/mxf/smp-te-st-377-1> - Last accessed: 15/12 2014
- [57] SMPTE 356M-2001 D10 Stream Specification, <https://www.prestocentre.org/standards/mxf/smp-te-st-356> - Last accessed: 15/12 2014
- [58] METS, <https://www.prestocentre.org/standards/mets/1.10> - Last accessed: 15/12 2014
- [59] PREMIS, <https://www.prestocentre.org/standards/premis/2.2> - Last accessed: 15/12 2014
- [60] BBC, EURIX, JRS & RAI contributed expert knowledge for the Standards Register
- [61] "D13.2 Report about Standardisation Activities: Progress to Year 3", APARSEN, [http://www.alliancepermanentaccess.org/wp-content/uploads/downloads/2014/06/APARSEN-REP-D13\\_2-01-1\\_5\\_incURN.pdf](http://www.alliancepermanentaccess.org/wp-content/uploads/downloads/2014/06/APARSEN-REP-D13_2-01-1_5_incURN.pdf) - Last accessed: 15/12 2014
- [62] "Standards and Projects Register", <http://fenugreek.fernuni-hagen.de:8080/StandardsWeb/home/standardsRegister.xhtml> - Last accessed: 15/12 2014

Deliverable D4.3 - Recommendations for Standards and Trusted Audiovisual Repositories

- [63] DPP Quality Control requirements [http://dpp-assets.s3.amazonaws.com/wp-content/uploads/2014/03/DPP\\_Quality\\_Control\\_Requirements\\_V1.0.pdf](http://dpp-assets.s3.amazonaws.com/wp-content/uploads/2014/03/DPP_Quality_Control_Requirements_V1.0.pdf) - Last accessed: 15/12/2014
- [64] Zack Lischer-Katz, 'Considering JPEG2000 for Video Preservation: A Battle for Epistemic Ground', 2014 <https://www.ideals.illinois.edu/handle/2142/47380> - Last accessed: 31/12/2014
- [65] Technical Specification: WAV & BWA  
<http://downloads.bbc.co.uk/commissioning/site/BBCRADIOTechSpec1.pdf> - Last accessed: 31/12/2014
- [66] Brian Campanotti, Chief Technology Officer of Front Porch Digital, in Claudia Kienzle, 'Strategies for Better LTO Data Preservation: How AXF Impacts LTO/LTFS Media Archiving', *TVTechnology*, 2014 <http://www.tvtechnology.com/news/0086/strategies-for-better-lto-data-preservation/223170>  
- Last accessed: 31/12/2014
- [67] Thomas Heritage, "File-Based Preservation of the BBC's Videotape Archive", INTERNATIONAL CONFERENCE ON PRESERVATION OF DIGITAL OBJECTS, 10, Lisboa, 2013 <http://purl.pt/24107/1/> - Last accessed: 31/12/2014
- [68] "Digitising the BBC archive",  
<http://www.bbc.co.uk/academy/technology/article/art20130704121742520> - Last accessed: 31/12/2014
- [69] Pericles Project, <http://pericles-project.eu> - Last accessed: 31/12/2014
- [70] DPC OAIS Doc (NOT PUBLISHED YET)  
[http://www.dpconline.org/component/docman/doc\\_download/1317-twrintroducingoais2ndeditionpreviewoctober2014](http://www.dpconline.org/component/docman/doc_download/1317-twrintroducingoais2ndeditionpreviewoctober2014)  
N.B. LOGIN BEFORE FOLLOWING LINK. The document will be made freely available to all in December 2014.
- [71] UK Data Archive <http://data-archive.ac.uk/curate/trusted-digital-repositories> - Last accessed: 31/12/2014
- [72] Richard Wrights, "The real McCoy: What Audiovisual Collections Preserve, BBC R&D Publications, <http://www.bbc.co.uk/rd/publications/whitepaper211> - Last accessed: 31/12/2014
- [73] APARSEN, "Report on peer review of digital repositories (Part B of D33.1)",  
[http://www.alliancepermanentaccess.org/wp-content/uploads/downloads/2012/04/APARSEN-REP-D33\\_1B-01-1\\_0.pdf](http://www.alliancepermanentaccess.org/wp-content/uploads/downloads/2012/04/APARSEN-REP-D33_1B-01-1_0.pdf) - Last accessed: 31/12/2014

Deliverable D4.3 - Recommendations for Standards and Trusted Audiovisual Repositories

[74] Trusted Digital Repositories, <http://www.trusteddigitalrepository.eu> - Last accessed: 31/12/2014

[75] Data Seal of Approval, <http://www.datasealofapproval.org> - Last accessed: 31/12/2014

[76] ISO 16363:2012, "Space data and information transfer systems – Audit and certification of trustworthy digital repositories". Also published as CCSDS 652.0-M-1 and available for free at <http://public.ccsds.org/publications/archive/652x0m1.pdf> - Last accessed: 31/12/2014

[77] DIN 31644, "Information and documentation - Criteria for trustworthy digital archives", <http://www.nabd.din.de/cmd?level=tpl-art-detailansicht&committeeid=54738855&artid=147058907&languageid=de&bcrumblevel=3> - Last accessed: 31/12/2014

[78] DANS, <http://www.dans.knaw.nl/> - Last accessed: 31/12/2014

[79] DRAMBORA, <http://www.dcc.ac.uk/resources/repository-audit-and-assessment/drambora>  
- Last accessed: 31/12/2014

[80] Centre for Research Libraries, Metrics for Repositories Assessment  
<http://www.crl.edu/archiving-preservation/digital-archives/metrics-assessing-and-certifying>  
- Last accessed: 31/12/2014

[81] Foundations of Modern Language Resource Archives,  
[http://pubman.mpd.l.mpg.de/pubman/item/escidoc:58934:4/component/escidoc:58935/Wittenburg\\_2006\\_foundations.pdf](http://pubman.mpd.l.mpg.de/pubman/item/escidoc:58934:4/component/escidoc:58935/Wittenburg_2006_foundations.pdf) - Last accessed: 31/12/2014

[82] Stewardship of Digital Research Data: A Framework of Principles and Guidelines,  
<http://www.rin.ac.uk/our-work/data-management-and-curation/stewardship-digital-research-data-principles-and-guidelines> (LOGIN REQUIRED) - Last accessed: 31/12/2014

[83] Data Seal of Approval, <http://www.datasealofapproval.org/en/information/all-documentation/> - Last accessed: 31/12/2014

[84] CESSDA, <http://www.cessda.net/> - Last accessed: 31/12/2014

[85] CLARIN, <http://clarin.eu/> - Last accessed: 31/12/2014

[86] DARIAH, <http://www.dariah.eu/> - Last accessed: 31/12/2014

[87] EUDAT, <http://www.eudat.eu/> - Last accessed: 31/12/2014

Deliverable D4.3 - Recommendations for Standards and Trusted Audiovisual Repositories

[88] The Trustworthy Repositories Audit & Certification

[http://www.crl.edu/sites/default/files/attachments/pages/trac\\_0.pdf](http://www.crl.edu/sites/default/files/attachments/pages/trac_0.pdf) - Last accessed: 31/12/2014

[89] "OAIS Compliant Preservation workflows in an AV archive: a requirement projects",

<http://www.avarchivering.nl/node/1822> - Last accessed: 31/12/2014

[90] "10 Things You Need to Know About Digital Storage",

<http://www.digitalproductionpartnership.co.uk/downloads/guides/> - Last accessed: 31/12/2014

[91] NDSA Levels of Preservation,

<http://www.digitalpreservation.gov/ndsa/activities/levels.html>

- Last accessed: 31/12/2014

[92] "Digital Preservation Maturity Model", [www.preservica.com/download/852](http://www.preservica.com/download/852) - Last accessed: 31/12/2014

[93] Walter Allasia, Werner Bailer, Sergiu Gordea and Wo Chang, "A Novel Metadata Standard for Multimedia Preservation," in Proceedings of iPres 2014, Melbourne, AU, Oct. 2014.

[94] Daniel J. Weitzner (ed.), W3C Patent Policy, Feb. 2004,

<http://www.w3.org/Consortium/Patent-Policy/> - Last accessed: 31/12/2014

[95] Carol Sliwa, W3C readies new tech patent policy, Computerworld, May 2003,

<http://www.computerworld.com/article/2570408/networking/w3c-readies-new-tech-patent-policy.html> - Last accessed: 31/12/2014

[96] Draft text of ISO/IEC DIS 23000-15 Multimedia Preservation Application Format

<http://mpeg.chiariglione.org/standards/mpeg-a/multimedia-preservation-application-format/draft-text-isoiec-dis-23000-15> - Last accessed: 31/12/2014

[97] SMPTE Standards - <http://www.smpte.org/standards> - Last accessed: 15/12/2014

[98] ISO, the International Organization for Standardization that develops and publishes

International Standards - <http://www.iso.ch> - Last accessed: 15/12/2014

Deliverable D4.3 - Recommendations for Standards and Trusted Audiovisual Repositories

## Document information

<b>Delivery Type</b>	Report
<b>Deliverable Number</b>	4.3
<b>Deliverable Title</b>	Interim Report on Audiovisual and Preservation Standards
<b>Due Date</b>	Dec 31 <sup>st</sup> 2014
<b>Submission Date</b>	2 January 2014
<b>Work Package</b>	4
<b>Partners</b>	KCL, EURIX, JRS, RAI, BBC, INA, Tate
<b>Authors</b>	K. Colbron, W. Allasia, W. Bailer, R. Borgotallo, L. Boch, J. Pellegrino, T. Heritage, S. Factor, P. Walland, A.Chakravarthy, L. Ligios, P. Laurensen, Daniel Teruggi
<b>Contributors</b>	Rebecca Squire Guenther, Ingrid Dillo, Lisa de Leeuw
<b>Reviewer</b>	Fabrizio Falchi (CNR)
<b>Keywords</b>	Digital Preservation, Standards, Multimedia, Audio Video Formats
<b>Document Identifier</b>	Deliverable_D4.3_presto4u_02_01_2015_v5(R).pdf
<b>Dissemination level</b>	PU
<b>Document Status</b>	Draft
<b>Project Acronym</b>	Presto4U
<b>Project Full Title</b>	European Technology for Digital Audiovisual Media Preservation
<b>Grant Agreement</b>	600845
<b>Project Coordinator</b>	Beeld en Geluid
<b>Contact Details</b>	Sumatrалаan 45, 1217GP Hilversum, The Netherlands. msnyders@beeldengeluid.nl

Deliverable D4.3 - Recommendations for Standards and Trusted Audiovisual Repositories

**Document Status Sheet (Revision History)**

Version	Status	Authors	Date	Changes
1.0	Draft	K. Kolbron, W. Allasia	31 July 2014	First draft discussed during the WP4 telco on July the 31st
2.0	Draft	Several authors	9 Oct 2014	New draft needing further improvements
3.0	Draft	Several authors	13 Nov 2014	Check status and refinement
3.1	Draft	W. Bailer	Late Nov 2014	Refinement of some sections
3.2	Draft	W. Allasia	3 Dec 2014	New introduction of Chapter 3
3.3	Draft	Several authors	4 Dec 2104	Refinements
3.4	Draft	W. Bailer, L. Ligios, W. Allasia	5 Dec 2104	Refinements
3.5	Draft	W. Allasia	8 Dec 2014	Added Executive Summary and refined introduction
3.6	almost Final Draft	W. Allasia	9 Dec 2014	Added conclusions
3.7	almost Final Draft	W. Allasia, L. Ligios	16 Dec 2014	Corrected references, improved conclusions
3.8	almost Final Draft	P. Walland, S. Factor	17 Dec 2014	Improved Chapter 6
3.9	almost Final Draft	W. Allasia	18 Dec 2014	Integrated and merged contributions from Tate, re-formatted text and sections, latest editorial refinements
4.0	Final Draft	W. Allasia	19 Dec 2014	Delivered to internal reviewer
4.1	Reviewed Draft	F. Falchi	30 Dec 2014	Reviewed for official release
5.0	Final and Reviewed Draft	W. Allasia	02 Jan 2015	Delivered to P4U Project Board
5(R)	Release	Coordinator	02 Jan 2015	Release

**Statement of originality**

This deliverable contains original unpublished work except where clearly indicated otherwise.

Acknowledgement of previously published material and of the work of others has been made through



Deliverable D4.3 - Recommendations for Standards and Trusted Audiovisual Repositories

appropriate citation, quotation or both.